

Quantum®

SuperLoader 3

User's Guide

6-68946-01, Rev. A

Quantum Product Name User's Guide, SuperLoader 3 Rev A, March 2022 Product of USA.

Quantum Corporation provides this publication "as is" without warranty of any kind, either express or implied, including but not limited to the implied warranties of merchantability or fitness for a particular purpose. Quantum Corporation may revise this publication from time to time without notice.

COPYRIGHT STATEMENT

© 2022 Quantum Corporation. All rights reserved.

Your right to copy this manual is limited by copyright law. Making copies or adaptations without prior written authorization of Quantum Corporation is prohibited by law and constitutes a punishable violation of the law.

TRADEMARK STATEMENT

Artico, Be Certain (and the Q brackets design), DLT, DXi, DXi Accent, DXi V1000, DXi V2000, DXi V4000, DXiV-Series, FlexTier, Lattus, the Q logo, the Q Quantum logo, Q-Cloud, Quantum (and the Q brackets design), the Quantum logo, Quantum Be Certain (and the Q brackets design), Quantum Vision, Scalar, StorageCare, StorNext, SuperLoader, Symform, the Symform logo (and design), vmPRO, and Xcellis are either registered trademarks or trademarks of Quantum Corporation and its affiliates in the United States and/or other countries. All other trademarks are the property of their respective owners. Products mentioned herein are for identification purposes only and may be registered trademarks or trademarks of their respective companies. All other brand names or trademarks are the property of their respective owners. Quantum specifications are subject to change.



Contents

Preface	xv
----------------	-----------

Chapter 1	Introduction	1
	Overview	1
	Host Interfaces	1
	Tape Drives	2
	Front Panel	2
	SuperLoader 3 LTO-4 and LTO-4 (Model C)	2
	SuperLoader 3 LTO-5 and LTO-5 (Model C)	3
	SuperLoader 3 LTO-6 and LTO-6 (Model C)	3
	SuperLoader 3 LTO-7	4
	SuperLoader 3 LTO-8	4
	SuperLoader 3 LTO-9	4

Chapter 2	Installation and Configuration	7
	Installation Overview	8
	SAS Interface	8
	Choosing a Location	8
	LTO-9 Environmental Specifications	9
	UL Requirements	11

Elevated Operating Ambient Temperature	11
Reduced Air Flow	11
Mechanical Loading	11
Overloading the Circuit.	11
Reliable Earthing (Grounding).	11
Unpacking the Autoloader	12
Accessories	12
Rack Mounting the Autoloader	13
Understanding Autoloader Features	14
General Features	14
Connecting Cables.	15
Connecting SAS and Power Cables	16
Preparing the Host and Verifying the Connection	17
Windows Operating System Support.	18
Autoloader Device Driver	18
Tape Drive Device Driver	18
Bar Code Reader	19

Chapter 3	Operating the Autoloader	23
	Operator's Panel Functionality	23
	Enter Passwords	25
	Logout	25
	Using Cartridges	26
	Inserting a Single Cartridge.	27
	Moving a Single Cartridge	28
	Ejecting a Single Cartridge	29
	Using Magazines and Magazine Blanks.	31
	Ejecting a Magazine	32
	Magazine Load/Unload Command	33
	Installing a Magazine	33
	Manually Operating the Magazine	33
	Viewing Status Information.	36
	Viewing SuperLoader 3 Autoloader Status	36
	Viewing Firmware Version	37
	Viewing Element Status	38
	Viewing Tape Drive Status	38

Viewing Tape Drive Version	39
Viewing Ethernet Information.	39
Running an Inventory	40
Data Compression	40

Chapter 4 On-board Remote Management 43

On-board Remote Management Overview	43
Opening On-board Remote Management.	44
Viewing Status Information	45
Default Username and Password	45
Time Display	45
Feedback on Pages	46
Configurations Page	46
System Operations	
Options.	46
Updates Page	57
Diagnostics Page	58
Running Diagnostic Tests	58
Viewing Error or History Logs	58
Diagnostics	59
Identification	59
Performing a System Reset	59
Commands Page	60
Inventory	60
Set to Home	60
Sequential Operations.	61

Chapter 5 Administration 63

Introduction	63
Configuring the Autoloader	64
SAS Autoloader*	67
Setting Ethernet	67
Setting the IP Address.	68
Setting the Subnet Mask.	69
Setting an IP Gateway.	69

Enabling SNMP	70
System Time	70
Setting the Time Zone.	71
Setting the Date and Time	71
Setting the Change Mode	72
Sequential Mode Operations	73
Setting Security	74
Setting Magazines.	75
Setting Passwords	75
Getting Lost Passwords.	76

Chapter 6 Diagnostics 79

Power-on Self Test (POST)	79
Performing a POST	80
Interpreting the POST Results	81
Diagnostic Tests from the Front Panel	81
Setting the Security.	82
Stopping a Diagnostic Test	82
Front Panel Diagnostic Tests	83
On-board Remote Management Diagnostic Tests	84
Diagnostics Using On-board Remote Management	85

Chapter 7 Customer Replaceable 87
Units (CRUs)

Replacing a Magazine or Magazine Blank	87
Removing a Magazine.	88
Removing a Magazine Blank.	88
Reinstalling a Magazine	89
Installing a Magazine Blank	89
Changing the Orientation.	89
Rack Mounting the Autoloader	92
General Preparation for Rack Mount Installation	94
Stationary Rack Mount Installation.	94

Chapter 8	Logs and Troubleshooting	101
	Before Contacting Customer Support	101
	Autoloader Logs	104
	Log Types	105
	Retrieving the Hard Log	106
	Hard Log Example	107
	Time Stamp	108
	Error Fields	108
	Tape Drive Logs	116
	Log Fields	117
	POST Failure Logs	118
	Returning the Autoloader for Service	118
	Preparing the Autoloader for Shipment	119
	Removing the Autoloader from a Rack	119
	Packing the Autoloader	120
Appendix A	Specifications	121
	Autoloader Specifications	122
	Autoloader Performance Specifications	123
	Autoloader Environmental Specifications	125
	Autoloader Power Specifications	125
	Autoloader Vibration Specifications	127
	Autoloader Shock Specifications	127
	Tape Drive Specifications	127
	LTO-4 and LTO-4 (Model C) Drive Specifications	128
	Media Capacity	128
	Media Specifications	128
	LTO-5 and LTO-5 (Model C) Drive Specifications	129
	Media Capacity	130
	Media Specifications	130
	LTO-6 and LTO-6 (Model C) Drive Specifications	131
	Media Capacity	131
	Media Specifications	131

LTO-7 Drive Specifications	132
Media Capacity	133
Media Specifications	133
LTO-8 Drive Specifications	134
Media Capacity	134
Media Specifications	134
LTO-9 Drive Specifications	135
Media Capacity	136
Media Specifications	136

Appendix B	Drive Error Logs	137
	Tape Drive Error Logs	137
	Error Log Display	137
	SCSI Check Condition Error Logs	138
	Bugcheck Error Logs (SDLT 600 only)	141
	Event Error Logs (SDLT 600 only)	143
	A500: Hard Read Error	143
	A501: SDLT Hard Write Error	145
	A502: SDLT Loader Communication Error	147
	A503: SDLT Drive Servo Error	148
	A507/A508: Directory Read Failure/Directory Write Failure	153

Appendix C	Regulatory Statements	159
	FCC Statement	159
	Taiwan Statement	160
	Japan Notice	160
	Canadian Notice (Avis Canadien)	160
	European Union Notice	161
	Product Safety Electrostatic Discharge	161
	Grounding Methods	162
	Environmental Compliance	162
	Disposal of Electrical and Electronic Equipment	163

Appendix D	Converting LTO-7 Media to LTO-8 Type M	165
-------------------	---	------------

Glossary		167
-----------------	--	------------

Contents



Figures

Figure 1	Front Panel Overview	14
Figure 2	Back Panel Overview	15
Figure 3	Cable Connectors (SAS Tape Drive)	16
Figure 4	Front Panel.	24
Figure 5	Left Magazine	31
Figure 6	Autoloader Status	36
Figure 7	System Menu Tree	66
Figure 8	Left Magazine	90
Figure 9	Removing the Screws from the Handle	91
Figure 10	Clearance Requirements for Rack Mounting	93
Figure 11	Required Parts for Installation	95
Figure 12	Installing Two Clip Nuts	96
Figure 13	Attaching Autoloader Brackets	97
Figure 14	Attaching Support Brackets	98
Figure 15	Sliding Autoloader into Rack	99
Figure 16	Front Alignment.	99
Figure 17	Connecting Support Brackets.	100
Figure 18	POST Failures Event Log Sample.	118

Figures



Tables

Table 1	Location Criteria	9
Table 2	Front Panel LEDs	24
Table 3	Firmware Version Fields	37
Table 4	Drive Status Fields	39
Table 5	Drive Version Fields	39
Table 6	Ethernet Information Fields	40
Table 7	POST Descriptions	80
Table 8	Probable Cause and Possible Solutions	102
Table 9	Log Retrieval Methods	106
Table 10	Error Type Listing and Suggested Actions	110
Table 11	Log Field Descriptions	117
Table 12	POST Failure Specific Fields	118
Table 13	Error Log Display Field Descriptions	138
Table 14	SCSI Check Condition Error Log Field Descriptions	138
Table 15	Sense Key Field Definitions	139
Table 16	ASC/ASCQ Field Descriptions	140
Table 17	Bugcheck Log Field Descriptions	142
Table 18	Error Event Logs Field Descriptions	143

Table 19	Hard Read Error/Hard Write Error Block Descriptor	144
Table 20	Hard Read /Hard Write Error Field Descriptions	144
Table 21	Hard Read Error/Hard Write Error Block Descriptor	145
Table 22	Hard Read Error/Hard Write Error Field Descriptions	146
Table 23	Loader Communication Error Block Description	147
Table 24	Loader Communication Error Field Description	147
Table 25	Drive Servo Error Block Descriptor	148
Table 26	Drive Servo Error Field Descriptions	149
Table 27	Directory Read Failure/Write Failure Block Descriptor	153
Table 28	Directory Read/Write Failure Field Descriptions	154



Preface

This document serves as an easy-to-use information source to familiarize Quantum customers and systems professionals with the SuperLoader 3 autoloader.

Audience

The primary audience for this document consists of end users installing and using the SuperLoader 3 autoloader.

Purpose

This document provides information on the SuperLoader 3 including:

- Product description
- Installation instructions
- Operation instructions
- Remote as well as front-panel administration of the autoloader
- Diagnostics
- Customer Replaceable Unit (CRU) procedures
- System log files as well as error logs
- Troubleshooting
- Specifications
- Regulatory compliance and statements

Document Organization

This document is organized as follows:

- [Chapter 1, Introduction](#), provides a brief product overview.
- [Chapter 2, Installation and Configuration](#), describes a typical installation, SCSI bus requirements, accessories, selecting a location for the autoloader, UL requirements, features and a product overview as well as a product components identification, the bar code reader, identifying product components, SCSI (or Fibre Channel or SAS) and power cable connection, preparing the host and verifying the connection, and installing device drivers.
- [Chapter 3, Operating the Autoloader](#), provides information about Operator Control Panel functionality, using cartridges, magazines and magazine blanks, viewing status information, running an inventory and data compression.
- [Chapter 4, On-board Remote Management](#), provides an On-board Remote Management overview, including the Configurations, Updates, Diagnostics and Commands pages.
- [Chapter 5, Administration](#), describes configuring the autoloader, setting the SCSI ID, Ethernet, time, change mode, security, magazines, and passwords.
- [Chapter 6, Diagnostics](#), provides POST information and diagnostic test information using the front panel and On-board Remote Management.
- [Chapter 7, Customer Replaceable Units \(CRUs\)](#), includes information about components you can service yourself.
- [Chapter 8, Logs and Troubleshooting](#), provides log descriptions, troubleshooting information, and information on returning the autoloader for service.
- [Appendix A, Specifications](#), provides autoloader and tape drive specifications.
- [Appendix B, Drive Error Logs](#), lists tape drive errors and SCSI check condition error logs, as well as bugcheck and event error logs for the SDLT 600 only.
- [Appendix C, Regulatory Statements](#), lists the applicable regulatory statements for the autoloader.

This document concludes with a glossary and index.

Notational Conventions

This document uses the following conventions:

Note: Notes emphasize important information related to the main topic.

Caution: Cautions indicate potential hazards to equipment and are included to prevent damage to equipment.

WARNING: Warnings indicate potential hazards to personal safety and are included to prevent injury.

- Right side of the autoloader — Refers to the right side as you face the component being described.
- Left side of the autoloader — Refers to the left side as you face the component being described.
- Power cycle — Means to turn the autoloader or system on, then turn them off (or off, then on).
- Dimensions in figures — All dimensions are shown with no units specified (Inches understood unless otherwise specified).

Related Documentation

Documents related to the Quantum SuperLoader 3 are shown below:

Document No.	Document Title	Document Description
81-81313-xx	Quantum SuperLoader 3 Quick Start Guide	This guide contains a sequence of steps recommended for unpacking, installing, and setting up your autoloader.
6-66751-xx	Quantum SuperLoader 3 Release Notes	This document contains information about new features and enhancements, resolved issues, and known issues for the associated release.

Contacts

Quantum company contacts are listed below.

Quantum Corporate Headquarters

To order documentation on the <Product Name> or other products contact:

Quantum Corporation (*Corporate Headquarters*)
1650 Technology Drive, Suite 700
San Jose, CA 95110-1382

Technical Publications

To comment on existing documentation send e-mail to:

doc-comments@quantum.com

Quantum Home Page

Visit the Quantum home page at:

<http://www.quantum.com>

Getting More Information or Help

StorageCare™, Quantum's comprehensive service approach, leverages advanced data access and diagnostics technologies with cross-environment, multi-vendor expertise to resolve backup issues faster and at lower cost.

Accelerate service issue resolution with these exclusive Quantum StorageCare services:

- **Service and Support Website** - Register products, license software, browse Quantum Learning courses, check backup software and operating system support, and locate manuals, FAQs, firmware downloads, product updates and more in one convenient location. Benefit today at:

<http://www.quantum.com/ServiceandSupport/Index.aspx>

- **eSupport** - Submit online service requests, update contact information, add attachments, and receive status updates via email. Online Service accounts are free from Quantum. That account can also be used to access Quantum's Knowledge Base, a

comprehensive repository of product support information. Sign up today at:

<http://www.quantum.com/ServiceandSupport/eSupport/Index.aspx>

- **StorageCare Guardian** - Securely links Quantum hardware and the diagnostic data from the surrounding storage ecosystem to Quantum's Global Services Team for faster, more precise root cause diagnosis. StorageCare Guardian is simple to set up through the internet and provides secure, two-way communications with Quantum's Secure Service Center. More StorageCare Guardian information can be found at:

<http://www.quantum.com/ServiceandSupport/Services/GuardianInformation/Index.aspx>

For further assistance, or if training is desired, contact Quantum Customer Support Center:

United States	800-284-5101 (toll free) 949-725-2100
EMEA	00800-4-782-6886 (toll free) +49 6131 3241 1164
APAC	+800 7826 8887 (toll free) +603 7953 3010

For worldwide support:

<http://www.quantum.com/ServiceandSupport/Index.aspx>

Worldwide End-User Product Warranty

For more information on the Quantum Worldwide End-User Standard Limited Product Warranty:

<http://www.quantum.com/serviceandsupport/warrantyinformation/index.aspx>



Chapter 1 Introduction

Overview

Data backup is essential to protect irreplaceable information. Backing up data to magnetic tape is an easy, cost-efficient method used by many small and medium businesses. However, most enterprises have so much data that a single backup tape is not enough; the information has to be spread across numerous tapes. To avoid constantly changing tapes manually, many tape backup systems include a Quantum SuperLoader 3 autoloader.

Each autoloader is a robot that includes a tape drive and one or two magazines for tape cartridges. The user's application can automatically load and unload tape cartridges as required for data backup or data retrieval. Quantum SuperLoader 3 auto-loaders provide a compact, high capacity, but low cost method for simple, unattended data backup.

Host Interfaces

The Quantum SuperLoader 3 connects to your host server via a Fibre Channel or Serial Attached SCSI (SAS) connection allowing the host to send data and commands automatically. You can also connect to the autoloader using an Ethernet connection to perform administrative functions and download system updates.

Tape Drives

Your Quantum SuperLoader 3 contains one of the following tape drives and one or two magazines capable of containing up to eight tape cartridges each.

- [SuperLoader 3 LTO-4 and LTO-4 \(Model C\)](#) (SAS)
- [SuperLoader 3 LTO-5 and LTO-5 \(Model C\)](#) (SAS)
- [SuperLoader 3 LTO-6 and LTO-6 \(Model C\)](#) (SAS)
- [SuperLoader 3 LTO-7](#) (SAS)
- [SuperLoader 3 LTO-8](#) (SAS)
- [SuperLoader 3 LTO-9](#) (SAS)

Note: The V92 release of SuperLoader 3 supports limited drives. For more information, see the *SuperLoader 3 V92 Release Notes* (6-66751)

Front Panel

The front panel on the autoloader includes a liquid crystal display (LCD) screen and four function keys. A scrolling menu on the LCD screen allows you to obtain information from the autoloader and enter commands. The front panel also includes two light emitting diodes (LEDs) indicating the auto-loader's ready status and error status.

A single tape cartridge can be inserted directly into the tape drive via a password-protected mailslot on the front panel (provided there is no cartridge already in the drive). You can also load a tape cartridge into a magazine slot (provided there is no cartridge already in the slot).

SuperLoader 3 LTO-4 and LTO-4 (Model C)

This autoloader is available as a Serial Attached SCSI (SAS) data storage device.

The Quantum SuperLoader 3 autoloader is equipped with a LTO-4 tape drive and contains up to sixteen (16) Ultrium 4 data cartridges when utilizing two magazines, providing a compressed capacity of 25.6 Terabytes and a sustained data transfer rate of:

- **Half Height LTO-4 Tape Drive:** 288 GB per hour (native) or as high as 576 GB per hour compressed (assuming 2:1 compression)

- **LTO-4 Tape Drive (Model C):** 120 Mb per second (native) or as high as 550 Mb per second compressed (assuming 4:1 compression)

The autoloader is compatible with the most popular operating systems and environments supporting a SAS interface but requires direct support from the operating system or a compatible backup application to take full advantage of its many features.

SuperLoader 3 LTO-5 and LTO-5 (Model C)

This autoloader is a Serial Attached SCSI (SAS) data storage device.

The Quantum SuperLoader 3 autoloader is equipped with a LTO-5 tape drive and contains up to sixteen (16) Ultrium 5 data cartridges when utilizing two magazines, providing a compressed capacity of 48 Terabytes and a sustained data transfer rate of:

- **LTO-5 Tape Drive:** 500 GB per hour (native) or as high as 1000 GB per hour compressed (assuming 2:1 compression)
- **LTO-5 Tape Drive (Model C):** 140 Mb per second (native) or as high as 550 Mb per second compressed (assuming 3:1 compression)

The autoloader is compatible with the most popular operating systems and environments supporting a SAS interface but requires direct support from the operating system or a compatible backup application to take full advantage of its many features.

SuperLoader 3 LTO-6 and LTO-6 (Model C)

This autoloader is a Serial Attached SCSI (SAS) data storage device.

The Quantum SuperLoader 3 autoloader contains a LTO6 SAS tape drive, and one or two magazines that can hold up to eight (8) cartridges each. The autoloader operates as a single SCSI ID/two LUN data storage device and provides a compressed capacity of just over 6 Terabytes and a sustained data transfer rate of:

- **LTO-6 Tape Drive:** 160 MB per second (native) or as high as 400 MB per second compressed (assuming 2.5:1 compression)
- **LTO-6 Tape Drive (Model C):** 160 MB per second (native) or as high as 540 MB per second compressed (assuming 3.5:1 compression)

The autoloader is compatible with the most popular operating systems and environments supporting a SAS interface but requires direct support from the operating system or a compatible backup application

to take full advantage of its many features, including drive hardware-based encryption.

SuperLoader 3 LTO-7

This autoloader is a Serial Attached SCSI (SAS) data storage device.

The Quantum SuperLoader 3 autoloader contains an LTO-7 SAS tape drive, and one or two magazines that can hold up to eight (8) cartridges each. The autoloader operates as a single SCSI ID/two LUN data storage device and provides a compressed capacity of just over 15 Terabytes and a sustained data transfer rate of 300 MB per second (native) or as high as 500 MB per second compressed (assuming 2.5:1 compression)

The autoloader is compatible with the most popular operating systems and environments supporting a SAS interface but requires direct support from the operating system or a compatible backup application to take full advantage of its many features, including drive hardware-based encryption.

SuperLoader 3 LTO-8

This autoloader is a Serial Attached SCSI (SAS) data storage device.

The Quantum SuperLoader 3 autoloader contains an LTO-8 SAS tape drive, and one or two magazines that can hold up to eight (8) cartridges each. The autoloader operates as a single SCSI ID/two LUN data storage device and provides a compressed capacity of just over 32 Terabytes and a sustained data transfer rate as high as 500 MB per second compressed (assuming 2.5:1 compression)

The autoloader is compatible with the most popular operating systems and environments supporting a SAS interface but requires direct support from the operating system or a compatible backup application to take full advantage of its many features, including drive hardware-based encryption.

SuperLoader 3 LTO-9

This autoloader is a Serial Attached SCSI (SAS) data storage device.

The Quantum SuperLoader 3 autoloader contains an LTO-9 SAS tape drive, and one or two magazines that can hold up to eight (8) cartridges

each. The autoloader operates as a single SCSI ID/two LUN data storage device and provides a compressed capacity of just over 45 Terabytes and a sustained data transfer rate as high as 900 MB per second compressed (assuming 2.5:1 compression)

The autoloader is compatible with the most popular operating systems and environments supporting a SAS interface but requires direct support from the operating system or a compatible backup application to take full advantage of its many features, including drive hardware-based encryption.



Chapter 2

Installation and Configuration

This chapter covers all aspects of installing the autoloader in your location. The following information is available:

- [Installation Overview](#) on page 8
- [Choosing a Location](#) on page 8
- [UL Requirements](#) on page 11
- [Unpacking the Autoloader](#) on page 12
- [Rack Mounting the Autoloader](#) on page 13
- [Understanding Autoloader Features](#) on page 14
- [Front Panel Overview](#) on page 14
- [Back Panel Overview](#) on page 15
- [Connecting Cables](#) on page 15
- [Preparing the Host and Verifying the Connection](#) on page 17
- [Windows Operating System Support](#) on page 18
- [Bar Code Reader](#) on page 19

Installation Overview

A Serial Attached SCSI (SAS) version of the autoloader is available when equipped with a LTO-4 and higher SAS tape drive (see [SAS Interface](#)).

SAS Interface

Installing the Serial Attached SCSI (SAS) autoloader consists of the following steps, which are explained in more detail later in this section:

- 1 Prepare to install your new Quantum SuperLoader 3 autoloader (see [Choosing a Location](#) on page 8).
- 2 Identify the accessories that come with the autoloader (see [Accessories](#) on page 12).
- 3 Install the autoloader in a computer rack or select a table or desktop near the host server. If installing a rack mount unit, refer to [Rack Mounting the Autoloader](#) on page 92.
- 4 Attach the SAS cable to the autoloader (SFF-8088 for LTO-8 and below, SFF-8644 for LTO-9 drives) and to the server's SAS host adapter (see [Connecting SAS and Power Cables](#) on page 16).
- 5 Attach the power cable to the autoloader and plug in the power cable to the nearest power outlet (see [Connecting SAS and Power Cables](#) on page 16). Power the autoloader on to ensure it passes the power on self-test (POST).
- 6 Install the device drivers (see [Windows Operating System Support](#) on page 18).

Choosing a Location

The autoloader is designed to fit in a standard 19-inch rack using either the long or short brackets (depending on the depth of the rack). Choose a location that meets the following criteria (see [appendix, Specifications](#)). The autoloader uses standard rack mounting hardware.

Table 1 Location Criteria

Criteria	Description
Rack requirements	Standard 19-inch rack with 2U (3.5 in.) of clearance.
Room temperature	10–35° C (50–95° F)
Power source	AC power voltage: 100–127 VAC; 200–240 VAC Line frequency: 50–60 Hz Note: Locate the AC outlet near the autoloader. The AC power cable is the product’s main disconnect device and must be easily accessible at all times.
Weight	14.1 kg (31 lb) unloaded 17.2 kg (38 lb) loaded with 2 magazines, 16 cartridges
Air Quality	Minimize sources of particulate contamination. Avoid areas near frequently used doors and walkways, cooling or exhaust vents, stacks of supplies that collect dust, printers, and smoke-filled rooms. Caution: Excessive dust and debris can damage tapes and tape drives.
Humidity	20–80% RH (non-condensing)
Clearance	Back: Minimum of 43.2 cm (17 in.) Front: Minimum of 68.6 cm (27 in.) Sides: Minimum of 5.08 cm (2 in.)

LTO-9 Environmental Specifications

SuperLoader3 systems with an LTO-9 drive require the additional environmental specifications:

Environmental Factors	Recommended ¹	Allowed ²	Shipping ³
Dry-Bulb Temperature	15 to 25°C (59 to 77°F)	15 to 35°C (59 to 95°F)	-23 to 49°C (-9 to 120°F)

Environmental Factors	Recommended ¹	Allowed ²	Shipping ³
Relative Humidity	20 to 50% (non-condensing)	20 to 50% (non-condensing)	5 to 80% (non-condensing)
Maximum Temperature Change	5° C per hour	5° C per hour	N/A
Maximum Humidity	5% per hour	5% per hour	N/A
Temperature Limitation for Humidity Conditions	Max Dew Point 22°C (72°F)	Max Dew Point 22°C (72°F)	Wet Bulb Temp <= 26°C (79°F)
Maximum Altitude	3048 m (10000 ft)	3048 m (10000 ft)	12192 m (40000 ft)

Definition of Terms:

¹ **Recommended:** The recommended operational/storage environmental envelope provides guidance on the environmental range for optimal performance and high reliability. This environmental range protects for 30-year archival storage. (Derate the maximum recommended dry-bulb temperature by 1°C/300 m above 1,800 m (1.8°F/1,000 feet above 6,000 feet)).

² **Allowed:** The allowable operational/storage environmental envelope defines the test limits to verify that the equipment will function within the environmental envelope. This environmental range is defined for operational storage of less than 6 months. (Derate the maximum dry-bulb temperature by 1°C/300 m above 900 m (1.8°F/1,000 feet above 3,000 feet)).

³ **Shipping:** When shipping media over extended environmental ranges, shipping times should be limited to minimize the duration of media being exposed to varying environmental conditions at lower and upper ranges.

The prolonged exposure to conditions outside the recommended range, especially approaching the extremes of the allowable operating environment, can result in decreased equipment reliability and longevity. An occasional short-term excursion into the allowable envelope is generally acceptable but may result in performance and reliability implications and higher power consumption. For additional information regarding tape cartridge storage, shipping and operational requirements, including acclimation requirements,

please visit www.quantum.com/lto-media, or refer to specific LTO tape media specifications provided by the LTO consortium at <http://www.lto.org> or specifications provided by the media manufacturer.

UL Requirements

Elevated Operating Ambient Temperature

When installed in a closed multi-unit rack assembly, the operating ambient temperature of the rack environment may be greater than the room ambient. Therefore, consideration should be given to installing the equipment in an environment compatible with the manufacturer's maximum recommended ambient temperature.

Reduced Air Flow

Installation of the equipment in a rack should be such that the amount of air flow required for safe operation of the equipment is not compromised.

Mechanical Loading

Mounting of the equipment in a rack should be such that a hazardous condition is not achieved due to uneven mechanical loading.

Overloading the Circuit

Consideration should be given to the connection of the equipment to the supply circuit and the effect that overloading of circuits might have on overcurrent protection and supply wiring. Appropriate consideration of equipment nameplate ratings should be used when addressing the concern.

Reliable Earthing (Grounding)

Reliable earthing of rack-mounted equipment should be maintained. Particular attention should be given to supply connections other than direct connections to the branch circuit, such as use of power strips.

Unpacking the Autoloader

Before you begin, clear a desk or table so that you have room to unpack the autoloader. Ensure that the work area is free from conditions that could cause electrostatic discharge (ESD). Discharge static electricity from your body by touching a known grounded surface, such as your computer's metal chassis.

The *Quantum SuperLoader 3 Quick Start Guide* included in the packaging describes how to unpack and inspect your autoloader correctly. Please locate the *Quantum SuperLoader 3 Quick Start Guide* and follow the directions.

Caution: If the room in which you are working differs from the temperature in which the autoloader was shipped or stored by 15° C (30° F) or more, let the autoloader acclimate to the surrounding environment for at least 12 hours before opening the shipping carton.

Unpack your new Quantum SuperLoader 3 autoloader carefully and inspect it for any damage that might have occurred during shipping.

- 1 Inspect the shipping box for damage. If you notice any damage, report it to the shipping company immediately.
- 2 Open the shipping box and remove the accessories package. Set the accessories package aside for now.
- 3 Lift the autoloader and padding out of the box and place it on the work surface, top facing up. *Do not set the autoloader on either end or sides.*
- 4 Carefully remove the shipping padding from the left and right sides of the autoloader. Then remove the bag from the autoloader.
- 5 Save the packing materials in case you need to move or ship the autoloader in the future.

Accessories

The following accessories are shipped with the Quantum SuperLoader 3 autoloader with a Fibre Channel or SAS interface:

- Quantum SuperLoader 3 Quick Start Guide

- One of the following drive kits:
 - SAS tape drive kits
 - SAS cable (LTO-8 and below)
 - Mini-SAS cable (LTO-9)
- Ethernet cable
- Hardware to rack mount the autoloader
 - Four autoloader brackets (two long and two short to accommodate different rack depths)
 - Two support brackets
 - Two sets (decimal and metric) of four support bracket 10-32 x 1/4 inch button head screws (two per support bracket)
- TORX® L-Key drivers (T8 and T10)
- Power cables
- Bar code labels
- Eight rack screws

You will also need the following parts if you want to place your SuperLoader 3 on a rack:

- Eight clip nuts
- C13/C14 power cable

Rack Mounting the Autoloader

To rackmount the autoloader, you need to select an open 2U computer rack location near the server that will host the autoloader.

For instruction on mounting the autoloader in a standard 19-inch rack, see [Rack Mounting the Autoloader](#) on page 92.

Understanding Autoloader Features

General Features

The autoloader is compatible with most operating systems and environments that support the SCSI, Fibre Channel, or SAS (Serial Attached SCSI) interface, but requires either direct support from the operating system or a compatible backup application to take full advantage of its many features.

Caution: Whenever you power cycle the autoloader, allow 10 seconds before turning the power back on. The power supply requires at least two to three seconds for the capacitors to discharge. This ensures a complete system reset on power down and may avoid system errors.

Figure 1 Front Panel Overview

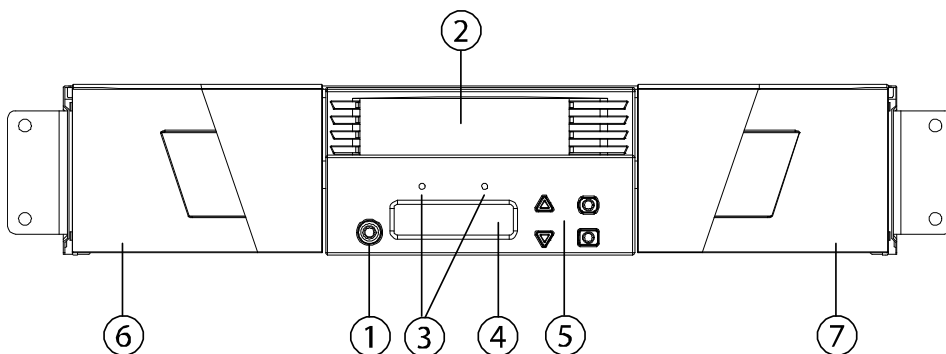

1	Power switch
2	Mailslot
3	Front panel LEDs
4	Front panel LCD screen
5	Function keys

6	Left magazine (or blank)
7	Right magazine (or blank)

Figure 2 Back Panel Overview

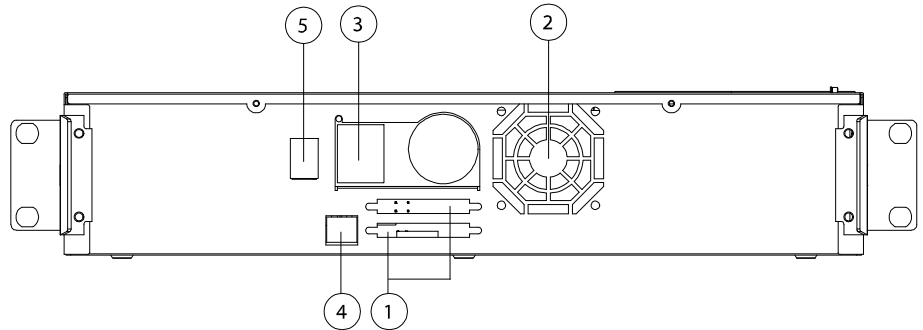

1	SAS Connector (LTO-8 and below) Mini-SAS Connector (LTO-9)
2	Fan vent
3	Power connector
4	Remote management Ethernet connector
5	Power switch

Note: If the cover must be taken off, there are 26 screws that need to be removed.

Connecting Cables

Connecting SAS and Power Cables

To connect the SAS and power cables to the autoloader, follow these steps:

- 1 Attach one end of the SAS cable (included in the accessory kit) to the SAS connector on the back panel of the autoloader (see [figure3](#)).

Figure 3 Cable Connectors
(SAS Tape Drive)

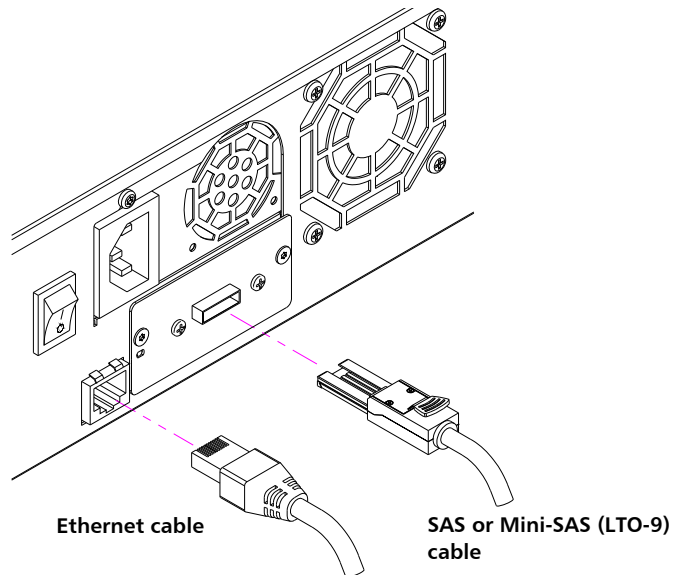

- 2 Attach the other end of the SAS cable to the SAS host.
- 3 Attach one end of your Ethernet cable to the Ethernet port on the back panel of the autoloader for remote management.
- 4 Attach the other end of the Ethernet cable to your host network port or router.
- 5 Attach the female connector of the power cable to the power connector on the back panel of the autoloader (see [figure2](#)).
- 6 Plug in the power cable to the nearest properly grounded power outlet.
- 7 Turn on the autoloader by setting the power switch on the back panel to the **ON** position. Turn on any other devices you turned off earlier. Check the LCD screen to make sure the autoloader is

receiving power. If it is not, check the power connections and your power source.

During the power on self-test (POST), both LEDs are illuminated briefly, followed by only the Ready/Activity LED flashing. When the initialization sequence is complete, the LCD screen displays the **Home** screen.

Preparing the Host and Verifying the Connection

If necessary, install a SAS host adapter, software, and compatible drivers. Refer to the manuals for the host computer and SAS host adapter for detailed instructions. In addition, follow these general guidelines:

- When the host server is powered on, install software, and/or drivers that are compatible with the autoloader (see [Windows Operating System Support](#) on page 18). Software compatibility information is available at www.quantum.com. Most backup software packages require an additional module to communicate with the autoloader robotics.
- If the host server is connected to a network, check with the system administrator before turning off power.
- Use proper procedures to prevent electrostatic discharge (ESD). Use wrist-grounding straps and anti-static mats when handling internal components.
- Make sure that the host server has an open expansion slot.
- Make sure that your backup application supports the SAS host adapter.

Windows Operating System Support

There are two device drivers associated with the SuperLoader 3 autoloader. One for the autoloader itself, and a second for the tape drive within the autoloader.

Note: Device drivers are required if you intend to use the Microsoft Windows native backup application. Commercial backup applications provide all necessary device driver support. Refer to www.quantum.com for a list of compatible backup applications.

Please note that Microsoft Windows NT[®] does not include native support for autoloaders. A backup application must be used if using the SuperLoader 3 autoloader under Microsoft Windows NT.

Autoloader Device Driver

- For the SuperLoader 3 autoloader, go to <https://www.quantum.com/en/service-support/downloads-and-firmware/superloader3/>

Tape Drive Device Driver

- For the LTO-4 SAS drive, go to: <https://www.quantum.com/en/service-support/downloads-and-firmware/lto-4hh>
- For the LTO-5 SAS drive, go to: <https://www.quantum.com/en/service-support/downloads-and-firmware/lto-5hh>
- For the LTO-6 SAS drive, go to: <https://www.quantum.com/en/service-support/downloads-and-firmware/lto-6hh>
- For the LTO-7 SAS drive, go to: <https://www.quantum.com/en/service-support/downloads-and-firmware/lto-7hh>

- For the LTO-8 SAS drive, go to:
<https://www.quantum.com/en/service-support/downloads-and-firmware/lto-8hh>
- For the LTO-9 SAS drive, go to:
<https://www.quantum.com/en/service-support/downloads-and-firmware/lto-9hh>

Bar Code Reader

The bar code reader is enclosed within the body of the autoloader. The bar code reader automatically scans each cartridge in the magazine upon power up, after a reset, after an import or export, or when a re-inventory command is issued (see [Running an Inventory](#) on page 40). Beyond that, there is no user interface with the bar code reader via the front panel operator controls or LCD screen. The information from each label is stored in memory and available through SCSI and On-board Remote Management to the computer's operating system or backup application upon request.

If utilizing the bar code reader, you must apply or slide the bar code labels into the appropriate slot on the front of each cartridge. The labels must conform to ANSI/AIM BC1 -1995 Uniform Symbology Specification Code 39. A set of bar code labels is initially included with the autoloader. Refer to www.quantum.com for information on obtaining additional bar code labels.

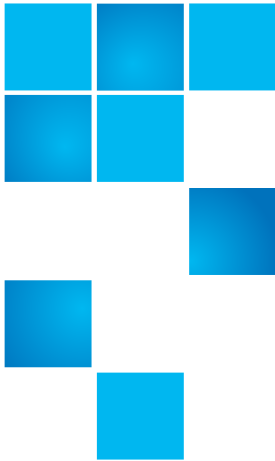

Chapter 3

Operating the Autoloader

This chapter covers all aspects of autoloader operation. The following topics are available:

- [Operator's Panel Functionality](#)
- [Using Cartridges](#) on page 26
- [Using Magazines and Magazine Blanks](#) on page 31
- [Viewing Status Information](#) on page 36
- [Running an Inventory](#) on page 40
- [Data Compression](#) on page 40

Operator's Panel Functionality

Note: If security is enabled and you try to execute a command without entering a password, the autoloader displays the **Enter Password** screen until you enter a password. Once you enter a password, the autoloader takes you back to the command screen that you were at prior to entering the password.

The front panel consists of two LEDs, four buttons, and a 2-line by 16-character LCD screen and provides everything you need to monitor autoloader status and to control all of its functions.

Figure 4 Front Panel

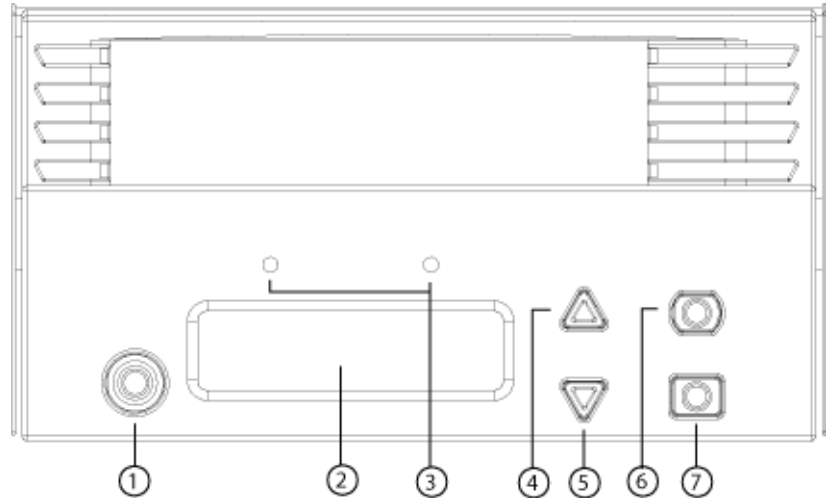

1	Power switch
2	Front panel LCD screen
3	Front panel LEDs
4	Scroll up button
5	Scroll down button
6	Escape
7	Enter

The functionality of the two front panel LEDs is defined in [table 2](#).

Table 2 Front Panel LEDs

Function	Green	Amber
Power off	OFF	OFF

Ready	ON	OFF
Normal activity	Flashing	OFF
Autoloader attention	OFF	Flashing
Autoloader error	OFF	ON

All the functionality accessed from the scrolling menu is password-protected. Two levels of security are built into the menu. The lower-level security is the operator level and the higher-level security is the administrator level. There is one password for each level.

The administrator password allows access to all the functionality available. The operator password allows access to all the functionality in the **Command** and **Status** sub-menus.

Enter Passwords

Many functions on the autoloader may be password-protected to ensure data integrity. To access the menu items necessary to execute these functions, you must first enter your password. All passwords are six numeric digits long.

When you enter a password, all password-protected functionality is available until you close your browser session. If you do not use the front panel for a period of time, the main screen displays on the LCD. When the main screen displays, the autoloader has automatically logged you out. You will have to re-enter your password again to access the menu functionality.

Logout

To log out of the autoloader:

- 1 From the main menu, scroll to **Commands**, and then press **Enter**.
- 2 From the **Commands** sub-menu, scroll to **Log Out**, and then press **Enter**. **Session Complete** displays on the LCD.

Note: You can also press **Escape** to log out. Continue pressing **Escape** as required until the main screen displays.

Using Cartridges

Typically, when you first install the autoloader, you load your cartridges into the magazines and then load the magazines into the autoloader. However, you can insert and eject cartridges individually using the mailslot, or you can eject a magazine, manually load and unload cartridges, then load the magazine back into the autoloader. The autoloader automatically detects the presence of a cartridge in the magazine slot.

Note: On the front panel menu, whenever you see **Enter** or **Eject**, it means the cartridge enters and leaves the autoloader through the mailslot. Whenever you see **Load** or **Unload**, it means the cartridge is loaded into or unloaded from the tape drive.

If you try to perform an illegal operation, the autoloader refuses to perform the operation. For example, if you try to load a cartridge through the mailslot to the drive, but the drive already contains a cartridge, the mailslot does not unlock. If you try to unload a cartridge from the drive while the autoloader is writing to the tape, the command will not be initiated until the write command is completed.

WARNING: If a tape cartridge is holding the mailslot door open on power up, the robot will not move. The system detects that the mailslot door is open but cannot detect the presence of the cartridge. If the mailslot door is open, the bar code scanner laser light may shine out the door and potentially cause physical injury.

With the mailslot door open, do not insert your hand through the mailslot door. This is to prevent bodily injury from the robot. Precautions are in place to prevent the robotic mechanism functioning in this circumstance.

If the tape cartridge is holding the mailslot door open during operation, the system keeps track of the tape movement and continues robotic motion. This can occur if the robot ejects the cartridge out through the mailslot door.

Inserting a Single Cartridge

When you want to load a single cartridge into the autoloader, you can use the mailslot. However, if the **Security** option is turned on, you have to enter a valid password to unlock the mailslot before you can load a cartridge. When you insert a cartridge through the mailslot, you can load it into the tape drive or store it in a magazine slot.

To insert a cartridge into the tape drive:

- 1 From the main menu, scroll to **Commands**, and then press **Enter**.
- 2 From the **Commands** sub-menu, scroll to **Enter**, and then press **Enter**.
- 3 From the **Enter** sub-menu, scroll to **To Drive**, and then press **Enter**. The message **Insert Tape, Push to Hard Stop** displays on the LCD.

Note: After **Insert Tape, Push to Hard Stop** displays on the LCD, insert the cartridge. After approximately 5 seconds, the system automatically verifies that a cartridge is inserted and continues the process. The message **Tape Loaded** displays when successfully completed.

Note: For the autoloader, push the cartridge in until it stops. The cartridge will be about 2 inches (5.0 cm) inside the mailslot. This may require that you push and have your fingers well within the mailslot opening. After insertion, the end of the cartridge will be visible at the back of the mailslot opening.

- 4 Once you have inserted the cartridge, press **Enter**.

Note: If the insert cartridge function fails, the cartridge ejects and you will have to repeat steps [3](#) and [4](#) again. The message **Missed Tape** displays.

- 5 Press **Exit** to clear the command and return to the menu.

To insert a cartridge into a magazine slot:

- 1 From the main menu, scroll to **Commands**, and then press **Enter**.
- 2 From the **Commands** sub-menu, scroll to **Enter**, and then press **Enter**.

- 3 From the **Enter** sub-menu, scroll to **To Location**, and then press **Enter**. The message **Insert Tape, Push to Hard Stop** displays on the LCD.

Note: After **Insert Tape, Push to Hard Stop** displays on the LCD, insert the cartridge. After approximately 5 seconds, the system automatically verifies that a cartridge is inserted and continues the process. The message **Tape Loaded** displays when successfully completed.

Note: For the autoloader, push the cartridge in until it stops. The cartridge will be about 2 inches (5.0 cm) inside the mailslot. This may require that you push and have your fingers well within the mailslot opening. After insertion, the end of the cartridge will be visible at the back of the mailslot opening.

- 4 Once you have inserted the cartridge, press **Enter**.

Note: If the insert cartridge function fails, the cartridge ejects and you will have to repeat steps [3](#) and [4](#) again. The message **Missed Tape** displays.

- 5 Press **Exit** to clear the command and return to the menu.

Moving a Single Cartridge

You can easily move a single cartridge from one location to another inside the autoloader.

- 1 From the main menu, scroll to **Commands**, and then press **Enter**.
- 2 From the **Commands** sub-menu, scroll to **Move**, and then press **Enter**.

The **Move** screen displays under **From:** Scroll to the current location of the cartridge you want to move. Slots that are occupied by a data cartridge are indicated by an asterisk (*).

- 3 From **To:**, scroll to the location to which you want to move the cartridge. Slots that are occupied by a data cartridge are indicated by an asterisk (*). Press **Enter**.
- 4 Press **Enter**.

If you select an empty location, **No Source Element** displays on the LCD. Choose a different location.

If you select a location that is already occupied, **Destination Full** displays on the LCD. Choose a different location.

Ejecting a Single Cartridge

When you want to remove a single cartridge from the autoloader, you can specify the cartridge you want by bar code or location, or choose the cartridge currently in the tape drive.

To eject a cartridge by bar code (if you have a bar code reader):

Note: This function is only allowed if the bar code reader is enabled.

- 1 From the main menu, scroll to **Commands**, and then press **Enter**.
- 2 From the **Commands** sub-menu, scroll to **Eject**, and then press **Enter**.
- 3 From the **Eject** sub-menu, scroll to **Tape**, scroll to **Mailslot**, and then press **Enter**.
- 4 Scroll to **By Barcode**.
A bar code label displays.
- 5 Scroll to the label that corresponds to the cartridge you want to eject. Press **Enter**.

To eject a cartridge by location:

- 1 From the main menu, scroll to **Commands**, and then press **Enter**.
- 2 From the **Commands** sub-menu, scroll to **Eject**, and then press **Enter**.
- 3 From the **Eject** sub-menu, scroll to **Tape**, scroll to **Mailslot**, and then press **Enter**.
- 4 Scroll to **By Location**.
Slots that are occupied by a data cartridge are indicated by an asterisk (*). The slot that is occupied by a cleaning tape is indicated with an at sign (@) if **Auto Clean** is enabled. Scroll to the slot containing the cartridge you want to eject.
- 5 Press **Enter**.

The cartridge you want is ejected from the mailslot.

To eject a cartridge from the tape drive:

- 1 From the main menu, scroll to **Commands**, and then press **Enter**.
- 2 From the **Commands** sub-menu, scroll to **Eject**, and then press **Enter**.
- 3 From the **Eject** sub-menu, scroll to **Cartridge**, and then press **Enter**.
- 4 Scroll to **From Drive**, and then press **Enter**.

The cartridge you want is ejected from the mailslot.

Using Magazines and Magazine Blanks

Figure 5 Left Magazine

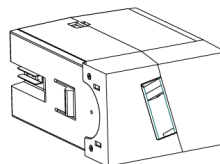
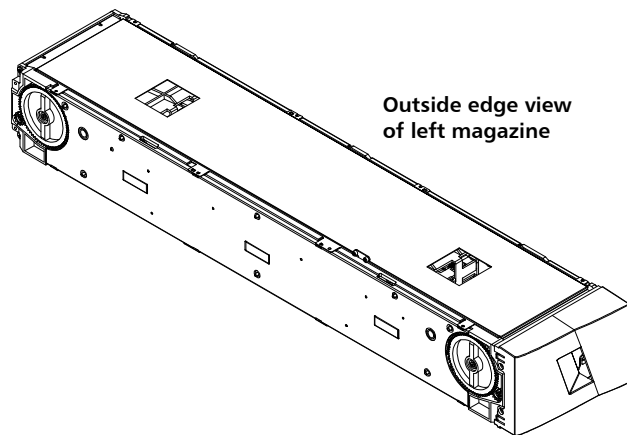
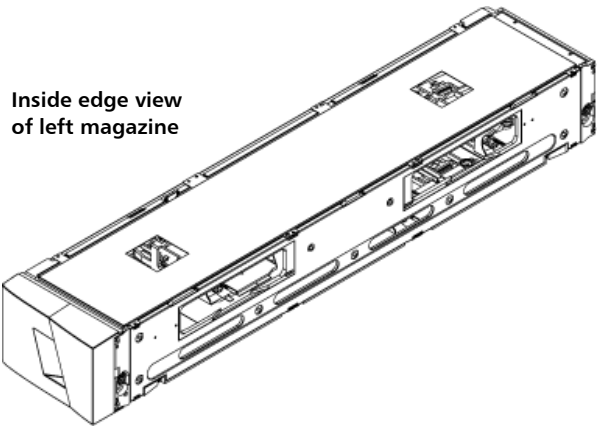

Left magazine blank

The autoloader will not run unless both magazine openings are properly closed. One way that you can close the openings is to use two magazines. If you use only one magazine, then you must fill the other magazine opening with a magazine blank for the unit to become operational.

Note: Magazines, magazine blanks, and magazine handles are not interchangeable between drive types. Please order the appropriate part numbers when replacing these items.

Ejecting a Magazine

When you want to remove several cartridges at once, eject the magazine(s) first.

To eject a magazine:

- 1 From the main menu, scroll to **Commands**, and then press **Enter**.
- 2 From the **Commands** sub-menu, scroll to **Eject**, and then press **Enter**.
- 3 On the **Eject** sub-menu, scroll to **Right Magazine** or **Left Magazine**, and then press **Enter**.

You will hear a distinctive popping sound as the appropriate magazine is ejected from the autoloader. **Left magazine has been ejected** or **Right magazine has been ejected** displays on the LCD.

Caution: To prevent damage to the autoloader or the magazine, use both hands when removing the magazine from the autoloader supporting, the entire length of the magazine.

- 4 Grasp the magazine by the handle with one hand and slide it out, supporting it underneath with the other hand.

Note: Once you eject a magazine, you must fully remove it or fully reinstall it before powering off the autoloader. Before returning a magazine to the autoloader, manually turn the wheels on the side of the magazine. If they move freely, the cartridges are properly seated. If the wheels do not turn freely, check the cartridges and remove and replace as needed.

Magazine Load/Unload Command

When issuing a Load/Unload command to the autoloader, the system automatically ejects the right-hand magazine. To remove the left-hand magazine using the Load/Unload command, you must:

- 1 Remove the right magazine.
- 2 Replace the right magazine with a magazine blank.
- 3 Issue the Load/Unload command again. The system will then eject the left magazine.
- 4 If you want to have the magazine in the right-hand bay, replace the magazine blank in the right-hand bay with a cartridge magazine.

Installing a Magazine

To install a magazine into the autoloader:

- 1 Grasp the magazine by the handle with one hand and support it underneath with the other hand.
- 2 Slide the magazine into the magazine bay until it clicks.

Make sure that you position the magazine correctly. It should slide into the magazine bay smoothly. If you meet resistance, verify the orientation of the magazine.

The magazine is correctly installed when you feel it click into place and the front is flush with the front panel. **Left Mag Inserted** or **Right Mag Inserted** displays on the LCD. The autoloader automatically proceeds to run an inventory.

Caution: Be careful not to turn the knob on the side of the magazine while the magazine is partially inserted into the autoloader. Doing so may cause damage to the magazine or the autoloader.

Manually Operating the Magazine

The following section describes how to operate a magazine.

There are two knobs located on each end of the magazine. You can move the slots within the magazine by turning these two knobs and aligning a slot with one of the two openings.

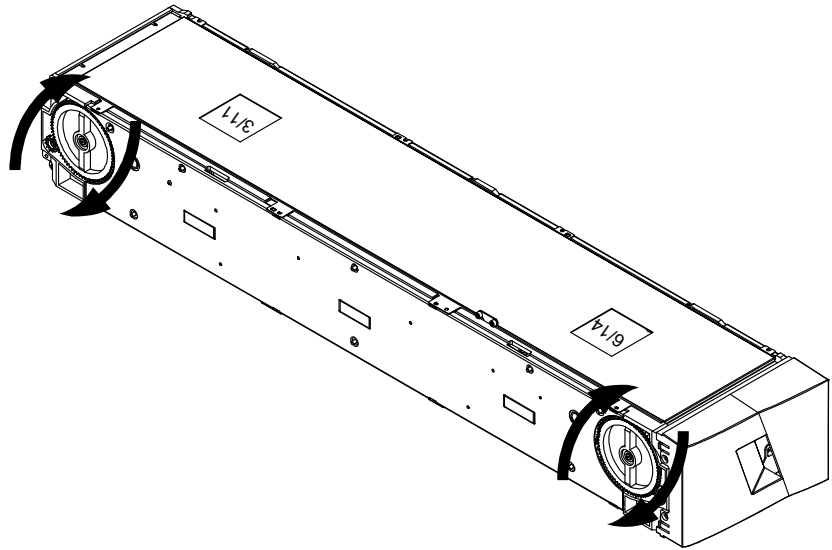

Do not rotate the magazine by inserting your hand and pushing the cartridge carriers. You can use the openings in the magazine to load and unload cartridges from the eight slots within each magazine.

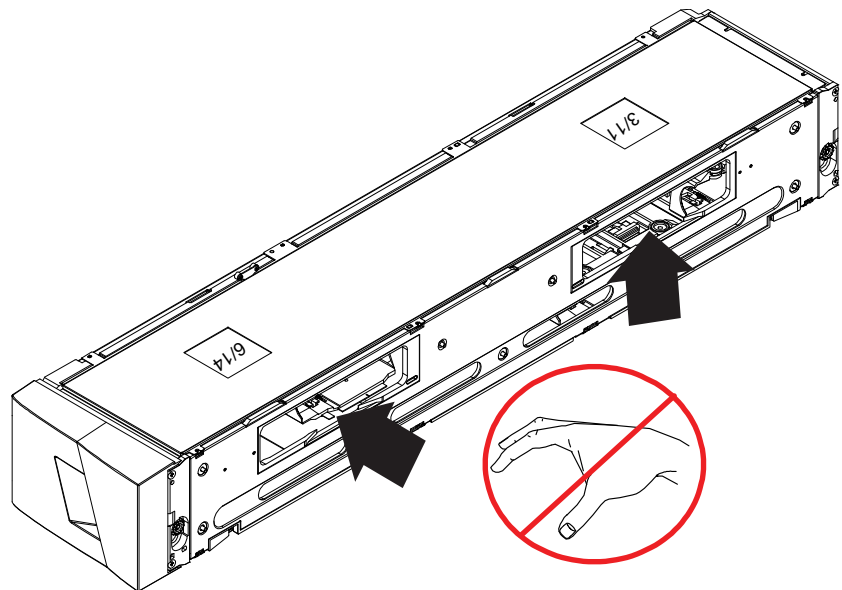

Caution: It is recommended that you fully remove the magazine to load and unload cartridges. If the magazine is not fully removed, do not rotate the magazine.

To Identify a Slot:

Each slot has an identification number that is exposed when the slots are in the upper section of the magazine. With the magazine removed from the autoloader, you can see the identification mark on the top side of the magazine through one of two windows on the upper surface of the magazine.

Each magazine carrier is labeled 1/9, 2/10, 3/11, and so forth. Lower numbers 1 - 8 reference slots in the left magazine. Higher numbers 9 - 16 reference slots on the right magazine if the optional right magazine is installed.

To Load Cartridges into a Fully Ejected Magazine:

- 1 To load cartridges into the magazine, center a slot within one of the openings located on the side of the magazine.
- 2 Properly orient the cartridge.

Note: There is a keying feature in each slot that only allows you to fully insert the cartridge one way.

- 3 Fully insert the cartridge into the slot.

When pushing the cartridge into the slot, you will feel a small resistance (detente) until the cartridge is properly latched into the slot. All forward progress stops when the cartridge is fully inserted.

You can remove a cartridge in the same manner as you insert it. Use the knobs to center the desired slot(s) in the openings on the side of the magazine. Using your thumb and index finger, pull out the cartridge. You will feel a small resistance, but continue to pull the cartridge until it comes free.

To Unload Cartridges from a Fully Ejected Magazine:

- 1 Pull the ejected magazine until the large upper slot is accessible.

- 2 Rotate the desired slot into position (centered in the opening). Either load or unload a cartridge to that location. Do not expose more than the large upper opening when manually operating the magazine.

Viewing Status Information

From the scrolling menu on the LCD, you can view the autoloader status, firmware version, element status, tape drive status, tape drive version, and Ethernet information.

Viewing SuperLoader 3 Autoloader Status

The autoloader status provides information about:

- Whether a magazine is installed or not
- SAS or Fibre Channel connection status
- Ethernet connection status
- Whether a bar code reader is installed or not

To view the autoloader status:

- 1 From the main menu, scroll to **Status**, and then press **Enter**.
- 2 From the **Status** sub-menu, scroll to **Autoloader**, and then press **Enter**.
- 3 From the **Autoloader** sub-menu, scroll to **Status**, and then press **Enter**.

A list of messages similar to the following displays:

Figure 6 Autoloader Status

Status	Message	Description
Magazines	L=*	The left magazine is present.
	R=*	The right magazine is present.

Status	Message	Description
SAS	SAS Interface	SAS connection.
Speed (Fibre Channel)	Auto Negotiate, 1 Gig, or 2 Gig	The configured Fibre Channel speed.
Loop ID (Fibre Channel)	0 – 127	Valid only with Topology set to Loop.
Mode	Random	The change mode is set to Random.
	SEQUENTIAL	The change mode is set to Sequential.
BC Reader	Yes or No	A bar code reader is present.

Viewing Firmware Version

To view the current firmware version, use the following procedure:

- 1 From the main menu, scroll to **Status**, and then press **Enter**.
- 2 From the **Status** sub-menu, scroll to **Autoloader**, and then press **Enter**.
- 3 From the **Autoloader** sub-menu, scroll to **Version**, and then press **Enter**.

A list of messages displays on the LCD. The firmware version is listed as **Firmware: VX.XX** where X.XX is the current installed version of the firmware.

Table 3 Firmware Version Fields

Field	Description
Firmware	The number indicates the firmware version.
EDC	The number indicates the Error Correction Code that was generated when the firmware was installed. The autoloader uses this number to verify that the firmware and the memory holding the firmware are good.
HW Rev	The number indicates the hardware version.
ME Rev	The number indicates the mechanical version.

Viewing Element Status

The element status reports the status of the magazine slots. The status indicates whether a slot contains a cartridge or not, and which slot is allocated as the cleaning cartridge's slot. To view an element's status:

- 1 From the main menu, scroll to **Status**, and then press **Enter**.
- 2 From the **Status** sub-menu, scroll to **Autoloader**, and then press **Enter**.
- 3 From the **Autoloader** sub-menu, scroll to **Element Status**, and then press **Enter**.
- 4 Press **Enter**.

You can scroll through each of the slots. Slots that are occupied by a data cartridge are indicated by an asterisk (*). The empty slot that is assigned to a cleaning cartridge is indicated with an exclamation point (!). The slot that is occupied by a cleaning cartridge is indicated with an at sign (@).

- 5 Scroll to the slot containing the cartridge for which you want to see the label, or the cartridge you want to move, and then press **Enter**.

The **Element Status** screen displays the bar code label for that cartridge. A move command also displays on the screen.

Note: The **Move** command displays only if the security is disabled or if you are logged in as administrator or operator.

If you want to move the cartridge, scroll until the location you want to move to displays under **To:**, and then press **Enter**. If you do not want to move the cartridge, press **Escape**.

Viewing Tape Drive Status

To view the tape drive status:

- 1 From the main menu, scroll to **Status**, and then press **Enter**.
- 2 From the **Status** sub-menu, scroll to **Drive**, and then press **Enter**.
- 3 From the **Drive** sub-menu, scroll to **Status**, and then press **Enter**.

A list of messages displays. These messages may include:

Table 4 Drive Status Fields

Field	Description
SAS Interface	Indicates a SAS drive.
Loader LUN	Indicates the Logical Unit Number (LUN) of the media changer device.
Compression	Indicates whether the tape drive compression is enabled or disabled.
Drive Tape	Indicates whether the tape drive is present or not.

Viewing Tape Drive Version

To view the tape drive version:

- 1 From the main menu, scroll to **Status**, and then press **Enter**.
- 2 From the **Status** sub-menu, scroll to **Drive**, and then press **Enter**.
- 3 From the **Drive** sub-menu, scroll to **Version**, and then press **Enter**.

A list of messages displays. These messages may include:

Table 5 Drive Version Fields

Field	Description
Product Type	Indicates the type of drive installed.
Version	Indicates the version number of the drive.

Viewing Ethernet Information

To view the Ethernet information:

- 1 From the main menu, scroll to **Status**, and then press **Enter**.
- 2 From the **Status** sub-menu, scroll to **Ethernet**, and then press **Enter**.

A list of messages displays. These messages may include:

Table 6 Ethernet Information
Fields

Field	Description
MAC Address	Indicates the unique network identifier associated with the autoloader.
IP Address	Indicates the static IP address or currently assigned dynamic IP address. The text DHCP displays in this case.
Network	Indicates whether the autoloader is connected to the network or not and at what speed.

Running an Inventory

The autoloader automatically runs an inventory whenever you power it back on or insert a magazine. An inventory checks each magazine slot, the drive, the picker, and the mailslot to determine if a cartridge is present. If so, it also reads the bar code label, if available. If you need to run an inventory in addition to this, you can do so manually.

Note: No bar code labels can be read if there is a tape in the picker.

To perform an inventory manually:

- 1 From the main menu, scroll to **Commands**, and then press **Enter**.
- 2 From the **Commands** sub-menu, scroll to **Inventory**, and then press **Enter**. The autoloader scans the bar codes of all the cartridges present.

Data Compression

Compressing the data means that the autoloader can write more data to the same amount of tape. Compression also increases the performance of the data transfers from or to the SCSI bus. The data

compression is drive dependent and cannot be set from the front panel or On-board Remote Management. Your backup application package may also have information on compression. The front panel display will indicate whether data compression is **Enabled** or **Disabled**.



Chapter 4

On-board Remote Management

This chapter covers the operation, configuration, and troubleshooting of the autoloader Remote Management Unit (RMU). The following topics are available:

- [On-board Remote Management Overview](#)
- [Configurations Page](#) on page 46
- [Updates Page](#) on page 57
- [Diagnostics Page](#) on page 58
- [Commands Page](#) on page 60

On-board Remote Management Overview

Your Quantum SuperLoader 3 autoloader firmware includes an Ethernet interface to allow remote administration of the autoloader. The interface, called the On-board Remote Management, includes a Web server that provides a Hypertext Markup Language (HTML)-based graphic user interface (GUI) for ease of use.

Many of the operations that you perform from the front panel, you can also perform remotely using On-board Remote Management. These functions include moving tapes, sequential operations, system

operations options, networking options, security options, running diagnostic tests, and performing system updates.

Note: Only use the **Diagnostic** command when the autoloader is known to be idle and unavailable to host backup/restore applications. Use of the **Diagnostic** commands from On-board Remote Management should not be issued while the autoloader is being used by host applications. The autoloader will recognize when the drive or autoloader is executing host commands and will respond appropriately to prevent application failures. A **Diagnostic** command being issued between host application commands may not be recognized resulting in a failed application, such as a failed backup/restore job.

Note: To log out of the system, you must close your browser to end the session.

Opening On-board Remote Management

On-board Remote Management has an HTML interface, which means you use a browser to open it. The following Web browsers are supported:

- For Microsoft Windows—Microsoft Internet Explorer 5.5 or later
- For Microsoft Windows Server 2003—Microsoft Internet Explorer 6.0 or later (with latest security patches)
- Microsoft Edge (latest version recommended)
- Google Chrome (latest version recommended)

You need an operator password to access the **Commands** page, and you need an administrator password to access the **Configurations**, **Diagnostics**, and **Updates** pages.

To open On-board Remote Management:

- 1 From your computer, open your Web browser.
- 2 In the browser's address field, enter the IP address for your autoloader (see [Viewing Ethernet Information](#) on page 39).

The **Home** page displays in your browser window.

Note: When using the On-board Remote Management page with Microsoft Internet Explorer, be sure to enable the Allow META **REFRESH** option.

On Internet Explorer version 6.0, this feature is controlled through the **Tools > Internet Options** menu selection under the **Security** tab.

Viewing Status Information

Status information displays on the right-hand side of the **Home** page and every page of On-board Remote Management except for the **Updates** page. The status information is updated every 10 seconds. Changes to the status appear in the status window update, but may take approximately 60 seconds to refresh. You can also click **Refresh Status** to get an immediate update of the system.

The menu headings also appear at the top of every page. To access the functionality under the menu heading, click the specific menu heading. The first time that you connect, On-board Remote Management prompts you for your username and password, then displays the opening page for that menu.

Default Username and Password

The default username for On-board Remote Management is **guest**. The default password is **guest**.

The username and password are case sensitive and should be entered in all lower case letters. The default username and password are valid if no usernames have been configured.

Time Display

The time displayed is either regular time or power-on time. Regular time is Month/Date/Year time, such as Nov/21/2004 19:28. Power-on time is Power On Cycles (POC)/Power On Hours (POH), such as POC:00121, POH:00002:07:45.

- POC (5-digit number) is the number of times the system has booted since it was manufactured.
- POH is the number of hours, minutes, and seconds that the system has been on since the current boot occurred.

Feedback on Pages

If there is feedback from the system when you submit a request, the feedback displays beneath the **Submit** button. In some cases, you may have to scroll to see the feedback information.

Configurations Page

The **Configurations** page includes a sub-menu on the left-hand side of the page. You can set the **System Operations**, **Networking**, and **Security** options from this page.

System Operations Options

The options listed under **System Operations** include **SAS**, **Mode**, **Compression**, **Cleaning Tape**, **Magazines**, and **System Time**.

SAS

You can select SAS parameters to enable or disable transport layer retries.

To set the **SAS** parameters:

- 1 From any page, click the **Configurations** heading. The **Configurations** screen displays.
- 2 In the **SAS** section of the page, the current selection is marked. To change the selection, select the other option. Click **Submit**.

Note: You must perform a system reset before the new mode takes effect, or you can use the front panel to power cycle your machine.

Mode

You can set the autoloader to either **Random** or **Sequential**. The default change mode is **Random**.

In **Random** mode, you (or the backup software) can specify which cartridge you want to use and where you want it to go. You will probably use this mode the most.

The **Sequential** mode supports certain backup applications that do not manage media. During backup, when one cartridge is read or written to the end of the tape, the autoloader automatically returns that cartridge to its slot and loads the cartridge from the next higher numbered slot to the tape drive to be read or written to. This continues until the backup software stops accessing the drive or until all the cartridges have been sequentially accessed. The autoloader does not move the media until the host requests the tape drive to unload the tape via a SCSI unload command.

Note: In **Sequential** mode, the medium changer does not appear in the **Device Manager**. The medium changer will reappear in **Device Manager** if you return the system to **Random** mode. This is to allow for operating systems that do not support multiple LUNs.

IMPORTANT: To use **Sequential** mode on **SL3 AutoLoaders** that use **IBM LTO-5, LTO-6, LTO-7, LTO-8, or LTO-9** tape drives, you must upgrade the **SL3 AutoLoader** to **V93** or greater.

If you are on a release earlier than **V93** and using **IBM** tape drives, if you enable **Sequential** Mode you might encounter errors during initialization after **Sequential** Mode has been set. You can recover from an error condition by doing the following:

- 1 Press **ESC** on the Operator Control Panel.
- 2 Change the mode back to **Random Mode**.
- 3 Cycle the power.

This solution works with **LTO-6 HH** drive firmware levels from **E6R8** and later. After the **SL3** completes initialization, you should upgrade the firmware to **V93** or greater as soon as possible. Also, upgrade the drive firmware if it is not at the latest level.

In **Sequential Cycle** mode, which is an option of the **Sequential** mode, the autoloader automatically starts over with magazine slot 1 when the last cartridge is used (slot 16 or highest filled slot). If this change mode is not set, the autoloader stops when the last cartridge available has been used. In **Sequential Cycle** mode, the autoloader continues to cycle until a user stops it.

To set the **Mode**:

- 1 From any page, click the **Configurations** heading. The **Configurations** screen displays.
- 2 In the **Mode** section of the page, the current mode is marked. To change the mode, select a different option. The **Sequential Cycle** check box is ignored if **Sequential** mode is not selected.
- 3 Click **Submit**.

Note: You must perform a system reset before the new mode takes effect, or you can use the front panel to power cycle your machine.

Compression

For the Quantum SuperLoader 3 autoloader, data compression is drive-dependent. The front panel and On-board Remote Management will display whether or not compression is enabled.

Compressing the data means that the drive can write more data to the same amount of tape. Compression also increases the performance of the data transfers from or to the SCSI bus.

Note: Compression cannot be changed from the front panel or On-board Remote Management of the autoloader.

To view the compression setting:

From any page, click the **Configurations** heading. The **Configurations** screen displays. Under the **Compression** heading, the current compression setting is displayed as **Compression Enabled** or **Compression Disabled**.

Cleaning Tape

To enable or disable the **Auto Clean** function, you must also designate a full slot for the cleaning tape cartridge. If a slot has not been designated, the box displays **None**. To designate the cleaning tape slot:

- 1 Load a cleaning tape into an empty slot using the **Commands** page.
- 2 Enable or disable **Auto Clean** by selecting the check box.

Note: To minimize the possibility of a cleaning conflict, it is preferable to allow the host to backup software to manage cleaning. If software managed cleaning is enabled, ensure **Auto Clean** is disabled on the SuperLoader 3.

To set **Auto Clean**:

- 1 From any page, click the **Configurations** heading. The **Configurations** screen displays.

- 2 Scroll to **Cleaning Tape**.

If a check mark displays in the box next to **Auto Clean**, the option is enabled. To disable **Auto Clean**, click the box to remove the check mark. If no check mark displays in the box next to **Auto Clean**, the option is disabled. To enable **Auto Clean**, click the box to enter a check mark.

- 3 In the **Cleaning Tape Location** field, select the appropriate slot location where you installed the cleaning tape. If **Auto Clean** is disabled, cleaning is managed by the backup package you have installed instead.

- 4 Click **Submit**.

Setting the Magazines

This setting is used to report the number of storage elements and the element address to the SCSI host. This setting must match the physical configuration in order for correct information to be reported. This setting only affects the information reported to the SCSI host. This setting does not affect the access to magazine slots from the front panel or On-board Remote Management. Those interfaces are based on the physical configuration.

Note: The default setting of **Left** must be reconfigured if the optional right magazine is installed. Host backup software may also require re-configuration if the loader was originally installed with only the default left magazine.

When configured for **Both** magazines, the autoloader always reports 16 storage elements to the SCSI host. This allows the removal and re-installation of magazines without affecting what is reported to the host.

When configured for **Left** or **Right**, the autoloader will always report eight storage elements to the SCSI host.

The element addresses vary depending on which magazine is configured. If **Left** or **Right** is selected, and both magazines are physically installed, the front panel and On-board Remote Management allow the user access to the other magazine, but the SCSI host will not have access.

To set the **Magazines** option:

- 1 From any page, click the **Configurations** heading. The **Configurations** screen displays.
- 2 Scroll to **Magazines**. The **Magazines** options display.
A check mark displays after the currently enabled mode.
- 3 Do one of the following:
 - To leave the **Magazines** mode unchanged, press **Esc**.
 - To change the **Magazines** configuration, scroll to the setting you want for the autoloader, selecting the appropriate check box, and then click **Submit**. These settings include **Both**, **Right**, and **Left**.

The message: This will require a power cycle and ISV configuration change. Enter To Continue is displayed.

- To continue with the change, press **Submit**. The message: Please power cycle the tape autoloader and reconfigure the ISV app. displays.

Setting the System Time

The system time is displayed by On-board Remote Management and is used internally for logging events and errors.

The time will be reset automatically if a time server is configured. Otherwise, the time must be set through On-board Remote Management. The time zone setting is not lost when powered off.

Note: If the time was set using On-board Remote Management, whether connected to a time server or not, the autoloader automatically corrects for daylight savings time. If the time does not properly correct for daylight savings time, you must correct for daylight savings time manually.

To set the system time:

- 1 Using the first drop-down list next to **Time Zone**, select the number of hours difference between your local time and Greenwich Mean Time (GMT).

Note: For example, if you live in Colorado, the time difference is – 6 hours in the summer and –7 hours in the winter.

- 2 Below the **Time Zone** field, select the current **Month** drop-down list.
- 3 In the **Day** field, type the current day of the month.
- 4 In the **Year** field, type the current year.
- 5 In the **Hour** text box, type the current hour in 24-hour format.
- 6 In the **Minute** text box, type the current minute.
- 7 Click **Submit** to save the information.

Setting Network Options

When you originally installed the autoloader, you set the Ethernet configurations through the front LCD panel. However, you can modify them through On-board Remote Management. The options include **Current Network Parameters**, **Set IP**, **Set Network Configuration**, and **SNMP**.

To view the **Current Network Parameters**:

- 1 From any page, click the **Configurations** heading. The **Configurations** screen displays.
- 2 From the **Configurations** menu, click **Networking**.

The **Current Network Parameters** area displays the current IP address, MAC address, and the speed setting for the Ethernet connection.

In the **Set IP** section, if a check mark displays in the box next to **DHCP**, the dynamic IP address option is enabled. This means that with every reset of the system, the IP address may change depending on the network administrator's settings.

To **Set IP** address:

- 1 Clear the check box to remove the check mark from the **DHCP** field, if applicable.
- 2 In the IP address fields, type the static IP address using the <Tab> key to move from box to box.
- 3 If no check mark displays in the box next to **DHCP**, the static IP address option is enabled. To change a static IP address, type in the new address in the IP address fields using the <Tab> key to move from box to box.
- 4 To change the IP address from a static address to a dynamic address, click the box next to **DHCP**.

To **Set Network Configuration**:

- 1 To change the values of the subnet mask, gateway, Simple Network Management Protocol (SNMP) server, or the time server, type in the new address, using the <Tab> key to move from box to box.
- 2 Click **Submit**.

SNMP

Simple Network Management Protocol (SNMP) is a light-weight protocol designed for remote management and monitoring of infrastructure devices.

SuperLoader 3 supports SNMP by publishing a Management Information Base (MIB), which provides library and component status to an external management application using SNMP traps and GET queries.

You must download the SNMP MIB from the [Quantum Support Website](#), which you can then install on an SNMP external management application.

Note: For more information about integrating MIBs with an SNMP management application, contact your network management application vendor.

Configuring SNMP Settings

By default, the SuperLoader 3 ignores all SNMP SET operations, meaning that external management applications cannot register themselves to receive SNMP traps from the SuperLoader3.

You can enable SNMP v1 on SuperLoader3. After enabling SNMP on SuperLoader 3, you can register transfer protocols, IP addresses, and port numbers of external management applications, which in turn enables them to receive SNMP traps from the library.

Note: We recommend running a test to verify that the library can send the SNMP traps to the addresses.

In addition, you will need an SNMP community string, which acts as a password to authenticate GET and GET-NEXT SNMP v1 messages exchanged between the library and an external management application. This SNMP community string must be the same for the library and the external management application.

The SNMP community string for SuperLoader 3 is **private**. You cannot change this SNMP community string.

To configure SNMP on SuperLoader 3:

Caution: If you are using a 1 GB/second Ethernet network interface, issues may occur when using SNMP with SuperLoader 3. To resolve such issues, disable SNMP

- To enable SNMP, select the **Enabled** radio button.
- To disable SNMP, select the **Disabled** radio button.

Note: After changing an SNMP setting, you must power cycle SuperLoader3 for the updates to take effect.

Setting Security Options

When you enable the security option, users must enter a password to access the autoloader's front panel functionality. A password allows either administrator-level access or operator-level access (see [Setting Security](#) on page 74). To set security:

- 1 From any page, click the **Configurations** heading. The **Configurations** screen displays.
- 2 On the left-hand side of the screen, click **Security**. The **System Security** section of the screen displays.
- 3 To enable front panel security, select the check box next to **Front Panel Security Enabled**.
- 4 If the check box is blank, the security option for the front LCD panel is not enabled.
- 5 Click **Submit**.

To reset the front panel password:

- 1 From any page, click the **Configurations** heading. The **Configurations** screen displays.
- 2 On the left-hand side of the screen, click **Security**.
- 3 Select the check box next to **Reset Front Panel Password**. A check mark displays.
- 4 Click **Submit**.

To set **User Administration**:

- 1 From any page, click the **Configurations** heading. The **Configurations** screen displays.
- 2 On the left-hand side of the screen, click **Security**.
- 3 From the drop-down list next to **Select User Type**, select **Operator 1**, **Operator 2**, **Administrator 1** or **Administrator 2**.
- 4 In the **Username** field, enter a user name.
- 5 In the **Password** field, enter the new password.
- 6 In the **Verify Password** field, re-enter the same new password.
- 7 Click **Submit**.

Note: To view the list of currently defined users, click **Submit** with **Select User Type**.

Note: To delete a user, **Select User Type** and click **Submit** with the **User Name** and **Password** fields blank.

To set the **Client Authorization Control**:

1 From any page, click the **Configurations** heading. The **Configurations** screen displays.

2 On the left-hand side of the screen, click **Security**.

Scroll to **Client Authorization Control**. In this section is a list of the IP addresses that are authorized to perform functions using On-board Remote Management for this specific unit. There are two sets of IP address boxes. You can individually enable/disable and configure each set.

- If enabled, each set can be used to specify either a range of IP addresses or a pair of specific IP addresses that are allowed to administer this unit. A set can also be used to specify a single IP address if the desired IP address is entered into both the "a" and "b" portions of the set. When a set is used to specify a range of IP addresses, the "b" portion of each address set must be greater than or equal to the "a" portion of that address set.
- If neither set is enabled, any IP client can administer the unit. If a single set is enabled, only clients that pass the test specified by that set are allowed administrator access. If both sets are enabled, any client that passes either of the two filter tests can administer the unit.

The Web server always allows any client to view the status information of the unit, regardless of the authorized client list or the overlap control policy.

3 Use the drop-down box to select **Enable** or **Disabled**.

4 Type the IP addresses in the appropriate boxes.

5 Click **Submit** to save.

Note: By entering an improper range of IP addresses, a user can possibly lock out all IP clients from administering the autoloader. If this occurs, the user can restore the default values by running **Restore Default** from the front panel **Configuration** menu.

Client Overlap Control is a management policy on controlling how the Web server handles overlapping control requests from multiple clients on the authorized client list. The options include **No Locking**, **Full Locking**, and **Time-Based Locking**.

- **No Locking** allows multiple clients to have unrestricted access to control the system as long as they are on the authorized client list.
- **Full Locking** permits only one authorized client to issue control requests at a time. This client must release the lock by clicking the **Home** option in the upper frame of the page to permit other authorized clients to have control access.
- **Time-Based Locking** is similar to **Full Locking** in that only one authorized client can have control access at once, but the lock is automatically released after the specified number of seconds of inactivity have elapsed.

After selecting the appropriate policy by clicking the check box, click **Submit** to save the changes.

- 1 From any page, click the **Configurations** heading. The **Configurations** screen displays.
- 2 On the left-hand side of the screen, click **Security**.
- 3 Select a security option from the **Client Overlap Control** options:
 - **No locking** allows multiple users to access the system and issue requests.
 - **Full Locking** allows only one user to access the system and issue requests.
 - **Time-based Locking** allows only one user to access the system and issue requests with the lock expiring after a designated amount of inactivity (in seconds).
 - **Home** is used to release a full or time-based lock and permit another user to access the system.

Note: Locking is only available to users on the authorized client list.

- 4 Click **Submit**.

Note: To log out of the system, you must close your browser to end the session.

Updates Page

You can browse to find system updates and then upload the updates. To get system updates:

- 1 From any page, click the **Updates** heading. The **Firmware Update** screen displays.
- 2 Click **Browse** to navigate to the host system for the update file. The file should end in an .img extension.
- 3 Click **Upload**.
- 4 Click **OK** in response to the confirmation box. The autoloader automatically uploads the new code and processes it to the system.

Note: A Microsoft issue can keep a user from updating drive or loader firmware over the On-board Remote Management interface. This can occur under Windows Server 2003 with Service Pack 1 (SP1), or if a user has installed Microsoft Security Update MS05-019. This problem will appear with a 6F Communication Error message on the front panel with the warning light on. On-board Remote Management will continue to report the autoloader status as **Initialization**.

Microsoft has described a workaround for this problem in their product with Technical Support Article 898060 (<http://support.microsoft.com/default.aspx?scid=898060>). If this problem occurs, the autoloader should be restarted to avoid further communication errors.

-
- 5 Power cycle the loader, then the server firmware update is complete.

Note: After firmware update is complete, the unit will report new revision levels to the host on startup. You may have to reconfigure you host backup software to recognize the updated unit.

Diagnostics Page

From the **Diagnostics** page, you can run various tests on the autoloader. You can also view error and history logs, test progress, identify the physical unit in a rack, or reset the system.

Running Diagnostic Tests

You can perform the following diagnostic tests from On-board Remote Management:

- Loader—Picker Test
- Loader—Magazine Test
- Loader—Inventory Test
- Random Moves

Note: On-board Remote Management allows you to request all diagnostic tests, but any tests that require a cartridge to be inserted will time out unless someone manually inserts the cartridge at the appropriate time.

Viewing Error or History Logs

To view error or history logs:

- 1 From any page, click the **Diagnostics** heading. The **Diagnostics** screen displays.
- 2 Under **View Error and History Logs**, click **View Logs**. You can also save the logs to a file by clicking **Save Logs**. If you save the logs to a file, you must select a destination folder within 60 seconds.

Note: **View Logs** allows you to view a summary of the hardware, software and update logs for the autoloader.

Save Logs saves detailed log information to a file for the autoloader. On some browsers, after saving logs, it may be necessary to click on **Home** to continue using the On-board Remote Management function.

Diagnostics

To view the various diagnostic options:

- 1 From any page, click the **Diagnostics** heading. The **Diagnostics** screen displays.
- 2 In the **Diagnostics** section, select the diagnostic test that you want to run from the **Test** drop-down menu.
- 3 Specify a loop count, if desired.
- 4 Click **Submit**.
- 5 While the test is running, you can view the status of the test. From **View Diagnostic Test Progress**, click **View Status**.

A separate screen indicates which test is running and the current status of the diagnostic test.
- 6 To refresh the status information, click **View Diagnostic Test Progress**, and then click **View Status** again.

Identification

You can use the **Identification** feature of the autoloader by requesting the LCD backlight to flash for a specified number of seconds. This can be helpful in identifying the location of the autoloader in an equipment room.

- 1 From any page, click the **Diagnostics** heading. The **Diagnostics** screen displays.
- 2 Under **Identification**, enter the number of seconds in the **Time (secs)** field.
- 3 Click **Identify**. The LCD backlight flashes on the autoloader for the specified number of seconds.

Performing a System Reset

You will use **System Reset** when making SCSI ID changes, mode changes, magazine changes, and IP address changes. A system reset will take at least three minutes if there is a tape in the drive, or approximately 30 seconds otherwise. To perform a system reset:

- 1 From any page, click the **Diagnostics** heading. The **Diagnostics** screen displays.
- 2 Under the **System Reset** section, click **System Reset**.

Commands Page

You can move tapes, run a system inventory, reset the picker to its home position, or perform sequential operations from the **Commands** page. When you click **Commands**, the page displays.

From a remote location, you can request that a tape be moved from one position to another. To move a tape:

- 1 From any page, click the **Commands** heading. The **Commands** screen displays.
- 2 From the **Moving Tapes** section of the page, click the drop-down menu under **From:** and select the current location of the tape that you want to move.

Note: You can also click the slot on the graphic of the autoloader magazine to select and move a cartridge.

- 3 From the drop-down menu under **To:**, select the location to which you want to move the tape, and then click **Submit**.

Inventory

The autoloader automatically runs an inventory whenever you power it on or insert a magazine. If you need to run an inventory in addition to this, you can use On-board Remote Management to do it remotely. To run an inventory:

- 1 From any page, click the **Commands** heading. The **Commands** screen displays.
- 2 From the **Commands** page, click **Inventory**. The autoloader starts an inventory immediately.

Set to Home

If the autoloader is not able to successfully execute a **Moving Tapes** or an **Inventory** command, try executing a **Set to Home** command, and then retry the move or inventory command again.

The **Set to Home** command resets the autoloader as a means to help the autoloader recover from an unexpected internal condition. To set to **Home**:

- 1 From any page, click the **Commands** heading. The **Commands** screen displays.
- 2 From the **Commands** page, click **Set to Home**. This executes a reset command to the autoloader.

Sequential Operations

The **Sequential Operations** mode supports certain backup applications that do not manage media. During backup, when one cartridge is read or written to the end of the tape, the autoloader automatically returns that cartridge to its designated slot and loads the cartridge from the next higher numbered slot to the tape drive to be read or written to. This continues until the backup software stops accessing the drive or until all the cartridges have been sequentially accessed. The autoloader does not move the media until the host requests the tape drive to unload.

Note: The loader must be in **Sequential** mode, selected from the **Configurations** page, to use **Sequential Operations**.

- 1 From any page, click the **Commands** heading. The **Commands** screen displays.
- 2 From the **Commands** page, scroll to **Sequential Operations**.
- 3 To start **Sequential Operations**, click **Start**. This moves the first available cartridge from the storage slot to the drive.
 - To stop **Sequential Operations**, click **Stop**. This removes the cartridge from the drive and places it back into the cartridge's previous storage slot.
 - To resume **Sequential Operations**, click **Resume**. This moves the next cartridge to the tape drive.

Note: You must perform a **Start** or **Resume** command to load a cartridge into the tape drive before starting a host backup.



Chapter 5 Administration

This chapter covers the information needed to interface the autoloader to the host network. The following topics are available:

- [Introduction](#) on page 63
- [Configuring the Autoloader](#) on page 64
- [Setting Ethernet](#) on page 67
- [Setting the Change Mode](#) on page 72
- [Setting Security](#) on page 74
- [Setting Magazines](#) on page 75
- [Setting Passwords](#) on page 75

Introduction

When you first power on the Quantum SuperLoader 3 autoloader, it automatically runs a power on self-test (POST). During the POST, the left (green) LED flashes. After the POST, the left (green) and right (amber) LED flash alternately back and forth. Do one of the following:

- If the autoloader powers on successfully, continue configuring the autoloader (see [Configuring the Autoloader](#)).

Note: The front panel requires a six-digit password to change the configuration (see [Setting Passwords](#) on page 75). The LCD front panel default password for the Administrator is **000000**. The default password for the Operator is **111111**.

- If the autoloader does not power on successfully, check the following:
 - Power switch is on.
 - Power cable is inserted correctly.
 - SAS cable is connected to the autoloader and host computer.
 - No error code displays on the autoloader LCD.
- If you cannot resolve the problem yourself, contact your service representative or go to www.quantum.com.

When you first power on the autoloader, the setting for the Internet Protocol (IP) address is static with the address **192.168.20.128**. If you want to use Dynamic Host Configuration Protocol (DHCP) to change the IP address, see [Setting the IP Address](#) on page 68. To determine the IP address when using DHCP, view the Ethernet status information (see [Viewing Ethernet Information](#) on page 39).

Configuring the Autoloader

To configure the autoloader, start with the main menu on the front panel. If the main menu is not already visible on the LCD, press **Enter**.

When you first power on the autoloader, the default is set with no password protection. However, after you set the security option, all the configuration functionality is password-protected. You need an administrator-level password to configure the autoloader.

To configure the Quantum SuperLoader 3 autoloader, you must verify the setup of the following:

- SAS autoloader.
- Magazine(s).

- Ethernet IP address (if you are not using DHCP).
- Time zone, date, and time.
- Control mode.
- Security option.

The front panel menu provides the following options (see [figure 7](#)):

Figure 7 System Menu Tree

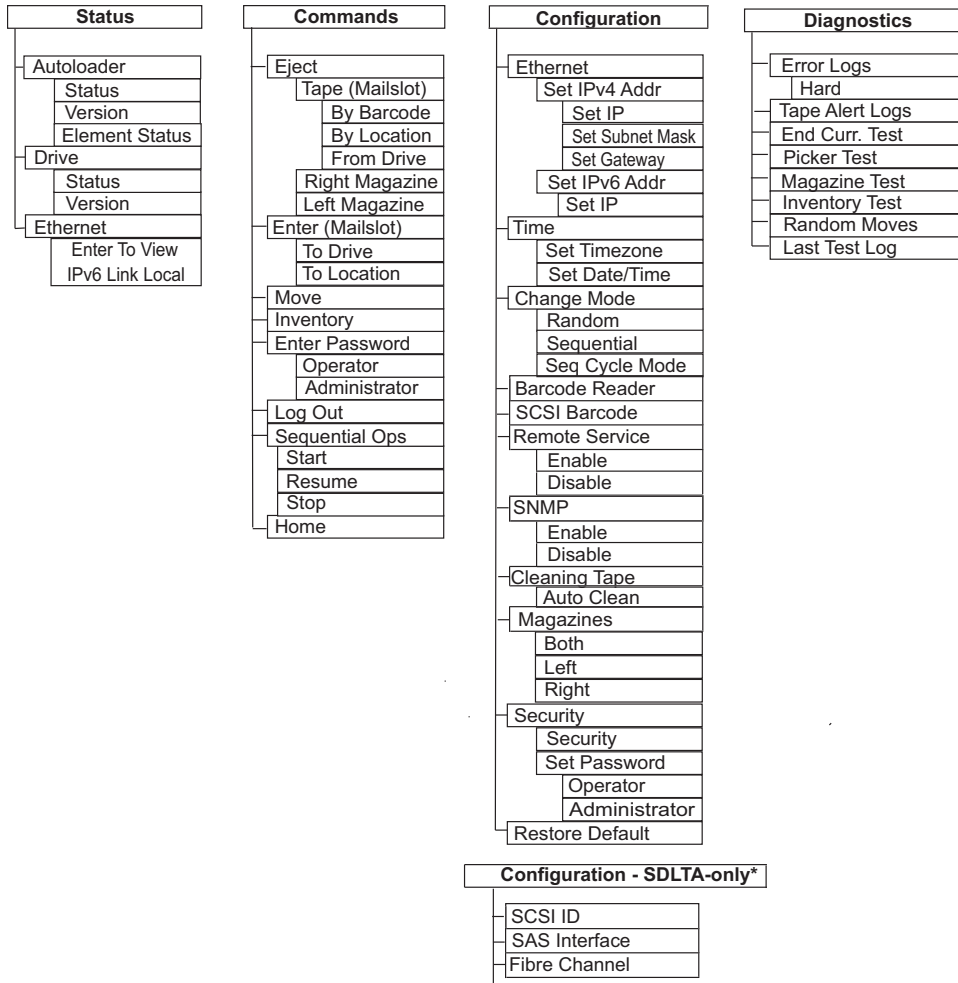

Note: * The **SAS Interface** and **Fibre Channel** menu options only appear under the **Configuration** menu for SDLTA.

SAS Autoloader*

If you have an autoloader with a SAS tape drive, **SAS** replaces **SCSI ID**.

To set or change the SAS parameters to enable or disable transport layer retries (TLR):

- 1 If the main menu is not already visible, press **Enter**.
- 2 On the main menu, scroll to **Configuration** and press **Enter**.
- 3 On the **Configuration** sub-menu, scroll to **SAS Interface** and press **Enter**.
- 4 Scroll to the parameter you want to set or change (**Enable or Disable transport layer retries**), then press **Enter**.
- 5 Press and hold the power button on the front panel when **Please Cycle Power** displays on the LCD.
- 6 **Power Off** displays on the LCD, then the autoloader shuts off.
- 7 Press the power button again to power on the autoloader.

The new SAS parameters are now in effect.

Setting Ethernet

Ethernet is the method used by the autoloader to access a network. With an Ethernet connection, you can remotely access the autoloader over the network. To use the Ethernet connection, you must define the following:

- A dynamic or static IP address for the autoloader (required)
- A subnet mask (required)
- An IP gateway (optional)
- Whether to enable Simple Network Management Protocol (SNMP) (optional)
- A time server, or set the time and time zone manually (optional)

Setting the IP Address

An IP address is the address of any device attached to a network. Each device must have a unique IP address. IP addresses are written as four sets of numbers separated by periods ranging from **0.0.0.0** up to and including **255.255.255.255**.

IP addresses are either permanent or dynamically assigned. A permanent, or static, address remains the same each time the device connects to the network. A dynamic address may change each time the device connects to the network server using Dynamic Host Configuration Protocol (DHCP).

To set a dynamic IP address:

- 1 From the main menu, scroll to **Configuration**, and then press **Enter**.
- 2 From the **Configuration** menu, scroll to **Ethernet**, and then press **Enter**.
- 3 From the **Ethernet** sub-menu, scroll to **Set IP**, and then press **Enter**.
- 4 Scroll to **DHCP**, and then press **Enter**. **Please reboot to use DHCP** displays on the LCD screen.
- 5 Press and hold the power button on the front panel until **System Shutdown wait 60 sec** displays on the LCD. **Power Off** displays on the LCD, then the autoloader shuts off.
- 6 Press the power button again to power on the autoloader. The IP address is changed.

To set a static IP address:

- 1 From the main menu, scroll to **Configuration**, and then press **Enter**.
- 2 From the **Configuration** menu, scroll to **Ethernet**, and then press **Enter**.
- 3 From the **Ethernet** sub-menu, scroll to **Set IP**, and then press **Enter**.
- 4 Scroll to **Static IP**, and then press **Enter**. The cursor automatically appears at the first digit.
- 5 At each position of the IP address, use the up and down arrows to change the value of each digit. Press **Enter** to advance the cursor to the next digit.

When you have advanced through all of the digits of the IP address, the autoloader displays **Enter to Save**.

Note: If you make a mistake, press **Escape** to backspace to the digit you want to change.

- 6 Press **Enter**. The **Configuration** sub-menu appears and the static IP is now in effect. You do not need to reboot the autoloader.
- 7 Press **Escape** or **Enter** to return to the Ethernet sub-menu.

Setting the Subnet Mask

Creating a subnet mask is a method of splitting IP networks into a series of subgroups, or subnets, to improve performance or security.

To set a subnet mask:

- 1 From the main menu, scroll to **Configuration**, and then press **Enter**.
- 2 From the **Configuration** menu, scroll to **Ethernet**, and then press **Enter**.
- 3 From the **Ethernet** sub-menu, scroll to **Set Subnet Mask**, and then press **Enter**.
- 4 At each position of the Subnet Mask address, use the up and down arrows to change the value of each digit. Press **Enter** to advance the cursor to the next digit.

When you have advanced through all of the digits of the subnet mask address, the autoloader displays **Enter to Save**.

Note: If you make a mistake, press **Escape** to backspace to the digit you want to change.

- 5 Press **Enter**. **New Subnet Mask xxx.xxx.xxx** appears on the LCD. You do not need to reboot the autoloader.
- 6 Press **Escape** or **Enter** to return to the Ethernet sub-menu.

Setting an IP Gateway

To set an IP gateway:

- 1 From the main menu, scroll to **Configuration**, and then press **Enter**.
- 2 From the **Configuration** menu, scroll to **Ethernet**, and then press **Enter**.

- 3 From the **Ethernet** sub-menu, scroll to **Set Gateway**, and then press **Enter**. The cursor automatically appears at the first digit.
- 4 At each position of the gateway address, use the up and down arrows to change the value of each digit. Press **Enter** to advance the cursor to the next digit.

When you have advanced through all of the digits of the gateway address, the autoloader displays **Enter to Save**.

Note: If you make a mistake, press **Escape** to backspace to the digit you want to change.

- 5 Press **Enter**. **New Gateway is xxx.xxx.xxx** appears on the LCD. You do not need to reboot the autoloader.
- 6 Press **Escape** or **Enter** to return to the Ethernet sub-menu.

Enabling SNMP

You can enable SNMP to send or receive packets. The default setting is **Disabled**. If you change this setting, you will need to power cycle the autoloader for the change to take effect. For more information about SNMP, see [SNMP](#) on page 52

Note: If you are using a 1 GB/second Ethernet network interface, issues may occur when using SNMP with SuperLoader 3. To resolve such issues, disable SNMP

To enable SNMP:

- 1 From the main menu, scroll to **Configuration**, and then press **Enter**.
- 2 From the **Configuration** menu, scroll to **SNMP**, and then press **Enter**.
- 3 From the **SNMP** sub-menu, scroll to **Enable**, and then press **Enter** to enable SNMP.

System Time

The system time is displayed by On-board Remote Management and it is used internally when logging events and errors. The system time is either regular time or power-on time. Regular time is Month/Date/Year Time, such as Nov/21/2004 19:28. Power-on time is Power On Cycles/Power On Hours. For example, POC: 00121, POH: 00002:07:45 where POC

is the number of times the system has booted since it was manufactured, and POH is the number of hours, minutes, and seconds since the last system boot. If regular time is known, it will be used, otherwise power-on time is used.

Setting the Time Zone

To set the time zone:

- 1 From the main menu, scroll to **Configuration**, and then press **Enter**.
- 2 From the **Configuration** menu, scroll to **Time**, and then press **Enter**.
- 3 From the **Time** sub-menu, scroll to **Set Timezone**, and then press **Enter**. The **Time Zone** screen appears, allowing you to set the hours. The cursor automatically appears at the first digit.
- 4 Scroll to set the number of hours difference between your local time and Greenwich Mean Time (GMT).
- 5 Scroll to set the number of minutes difference between your local time and GMT, then press **Enter**. The new time zone is set.
- 6 Press **Escape** or **Enter** as necessary to return to the main menu.

Setting the Date and Time

To set the date and time:

- 1 From the main menu, scroll to **Configuration**, and then press **Enter**.
- 2 From the **Configuration** menu, scroll to **Time**, and then press **Enter**.
- 3 From the **Time** sub-menu, scroll to **Set Date/Time**, and then press **Enter**. The **Date/Time** screen appears, allowing you to set the date and time. The cursor automatically appears at the first digit.
- 4 The first four digits represent the current year. At each position of the year, use the up and down arrows to change the value of each digit. Press **Enter** to advance the cursor to the next digit.
- 5 The next two digits represent the current month. At each position of the month, use the up and down arrows to change the value of each digit. Press **Enter** to advance the cursor to the next digit.
- 6 The next two digits represent the current day. At each position of the day, use the up and down arrows to change the value of each digit. Press **Enter** to advance the cursor to the next digit.

- 7 The next two digits represent the current hour. At each position of the hour, use the up and down arrows to change the value of each digit. Press **Enter**.
- 8 The last two digits represent the current minute. At each position of the minute, use the up and down arrows to change the value of each digit. Press **Enter** to advance the cursor to the next digit.
- 9 Press **Enter** to save.
- 10 Press **Escape** as necessary to return to the main menu.

Setting the Change Mode

You can set the autoloader to either **Random** or **Sequential**. The default change mode is **Random**.

In **Random** mode, you, or the backup software, can specify which cartridge you want to use and where you want it to go. You will probably use this mode the most.

The **Sequential** mode supports certain backup applications that do not manage media. During backup, when one cartridge is read or written to the end of the tape, the autoloader automatically returns that cartridge to its slot and loads the cartridge from the next higher numbered slot to the tape drive to be read or written to. This continues until the backup sequentially accessed. The autoloader does not move the media until the host requests the tape drive to unload the tape via a SCSI unload command.

Note: In **Sequential** mode, the medium changer does not appear in the **Device Manager**. The medium changer will reappear in **Device Manager** if you return the system to **Random** mode. This is to allow for operating systems that do not support multiple LUNS.

In **Seq Cycle** mode, which is an option of the **Sequential** mode, the autoloader automatically starts over with magazine slot 1 when the last cartridge is used (slot 16 or highest filled slot). If this change mode is not set, the autoloader stops when the last cartridge available has been

used. In **Seq Cycle** mode the autoloader continues to cycle until a user stops it.

IMPORTANT: To use Sequential mode on SL3 AutoLoaders that use IBM LTO-5, LTO-6, LTO-7, LTO-8, or LTO-9 tape drives, you must upgrade the SL3 AutoLoader to V93 or greater.

To set the **Change Mode**:

- 1 From the main menu, scroll to **Configuration**, and then press **Enter**.
- 2 From the **Configuration** menu, scroll to **Change Mode**, and then press **Enter**. the mode options appear. A check mark appears next to the currently enabled mode.
- 3 Do one of the following:
 - To leave the mode the same, press **Escape**.
 - To modify the change mode, scroll to the mode to which you want to set the autoloader and press **Enter**. **Reboot to enable new mode** appears on the LCD.
- 4 Press and hold the power button on the front panel until **System Shutdown wait 60 sec** appears on the LCD. **Power Off** appears on the LCD and the autoloader shuts off.
- 5 Press the power button again to power up the autoloader. The new change mode is now in effect.

If you are on a release earlier than V93 and using IBM tape drives, if you enable Sequential Mode you might encounter errors during initialization after Sequential Mode has been set.

You can recover from an error condition by doing the following:

- 1 Press **ESC** on the Operator Control Panel.
- 2 Change the mode back to **Random Mode**.
- 3 Cycle the power.

Sequential Mode Operations

If you enable **Sequential** mode, you must use the **Sequential Ops** sub-menu under the **Commands** menu to operate the autoloader after you reboot.

- The **Start** command allows you to load the first cartridge.

- The **Resume** command allows you to continue from the next unused slot, if a user stopped the cycle.
- The **Stop** command allows you to stop the cycle.

To start **Sequential** mode operation:

- 1 From the main menu, scroll to **Commands**, and then press **Enter**.
- 2 From the **Commands** menu, scroll to **Sequential Ops**, and then press **Enter**.
- 3 From the **Sequential Ops** menu, scroll to **Start**, and then press **Enter**. **Moving first tape to drive** appears on the LCD.

To stop **Sequential** mode operation:

- 1 From the main menu, scroll to **Commands**, and then press **Enter**.
- 2 From the **Commands** menu, scroll to **Sequential Ops**, and then press **Enter**.
- 3 From the **Sequential Ops** menu, scroll to **Stop**, and then press **Enter**. **Ejecting tape from drive** appears on the LCD.

To resume **Sequential** mode operation:

- 1 From the main menu, scroll to **Commands**, and then press **Enter**.
- 2 From the **Commands** menu, scroll to **Sequential Ops**, and then press **Enter**.
- 3 From the **Sequential Ops** menu, scroll to **Resume**, and then press **Enter**. **Moving next tape to drive** appears on the LCD.

Setting Security

You can add security to the front panel by password-protecting the autoloader's functionality. The security setting only protects the front panel functionality. The default setting is **Off**, meaning that no password is required. However, you can enable the security option so that users must enter a password to access functionality.

When you first power on the autoloader, the security option is set to **Off**. Use the following procedure to enable the security option. You must have an administrator-level password to set passwords.

To set the security option:

- 1 From the main menu, scroll to **Configuration**, and then press **Enter**.
- 2 From the **Configuration** menu, scroll to **Security**. If a check mark appears after the word, the security option is **On**. If no check mark appears, the security option is **Off**.
- 3 To change the option, press **Enter**. For example, if the security option was set to **On**, it is now set to **Off**, and no check mark appears.

Setting Magazines

In some cases, autoloader owners were being charged Independent Software Vendor (ISV) licensing fees for two-magazine SuperLoader 3s although only one magazine was configured. This occurred because the ISV software was registering the autoloader as a two-magazine device, regardless of the number of magazines configured. You have the ability to set the number of magazines in the autoloader.

To set the number of magazines:

- 1 From the main menu, scroll to **Configuration**, and then press **Enter**.
- 2 From the **Configuration** menu, scroll to **Magazines**, and then press **Enter**.
- 3 From the **Magazines** menu, select either **Right**, **Left**, or **Both** to indicate the magazines installed in the autoloader.

Setting Passwords

Many operations on the autoloader are password-protected to ensure data integrity. You can set passwords to administrator level and to operator level. Operator-level users have access to the **Commands** and **Status** menus. Administrator-level users have access to all functionality.

To set a password:

- 1 From the main menu, scroll to **Configuration**, and then press **Enter**.
- 2 From the **Configuration** menu, scroll to **Set Password**, and then press **Enter**.
- 3 To set a password to the operator level, scroll to **Operator**. To set a password to the administrator level, scroll to **Administrator**, then press **Enter**. The **Set Password** screen appears.
- 4 Press **Enter**. If you are not logged in as Administrator, press **Enter** again to log in. A text box appears above the first asterisk.
In the text box, scroll to the first character of the password. The cursor automatically appears at the first number of the password.
- 5 At each position of the password, use the up and down arrows to change the value of each number. Press **Enter** to advance the cursor to the next number.

Note: If you make a mistake, press **Escape** to backspace to the digit you want to change.

- 6 Press **Enter**. The text box above the asterisk disappears and another text box appears above the next asterisk.
- 7 Repeat steps [5](#) and [6](#) to enter the remaining digits of the password. When you have entered six numbers, the autoloader displays **Submit Password** below the asterisks.
- 8 Press **Enter** to submit the password. **Password Successfully Changed** appears on the LCD.
- 9 Press **Enter**. The Operator and Administrator options reappear. You can either enter another password, or press **Escape** or **Enter** as necessary to return to the main menu.

Getting Lost Passwords

If you forget the administrator-level password, you cannot access the autoloader's functionality to enter a new password. In this case, you must call customer support. When you call, have the autoloader connected to the Ethernet and open On-board Remote Management.

Note: You can reset front panel passwords to the factory defaults from On-board Remote Management. However, if the On-board Remote Management passwords are lost, you must contact customer support. If you must contact customer support, be at the host computer with On-board Remote Management on line. From the main screen, click **Configuration**. The enter **Network Password** or **User name** screen displays. The customer support representative will need the number surrounded by asterisks to locate and reset your password. This is your "realm number."



Chapter 6 Diagnostics

This chapter provides troubleshooting information that might be helpful with problems encountered during autoloader operation.

- [Power-on Self Test \(POST\)](#)
- [Diagnostic Tests from the Front Panel](#)
- [On-board Remote Management Diagnostic Tests](#)

Power-on Self Test (POST)

This section describes the POST and its various tests and also explains how to perform diagnostic tests from the front panel and from the On-board Remote Management interface.

The Power-on Self Test (POST) and diagnostic tests are helpful tools for testing the autoloader's functionality and for troubleshooting errors.

With the results from the POST and diagnostic tests, you can determine how well the autoloader is working and locate any problems

Every time you turn on the autoloader, the POST checks all of the autoloader's basic components. If you experience problems with the autoloader, the POST is a good method to determine if any major parts are malfunctioning.

Table 7 POST Descriptions

POST	Test Description
MICROP	Tests the microprocessor's general-purpose registers
IRAM	Tests the microprocessor's internal RAM
Addr Lines	Bit walks the SRAM address lines
SRAM	Tests the 512K SRAM
Code Chksum	Verifies the Flash image checksum
EERom	Checks the EERom area and verifies the checksums
PLL Clock	Tests that the microprocessor's PLL is synchronized correctly
LCD	Verifies that the LCD is present and working correctly
Ethernet	Configures and verifies communication with the Ethernet chip
Barcode	Verifies that the bar code reader is present and performs a hardware handshake
Temperature Sense	Pass/Fails the MDM and configures the AHIM temperature sensors
MDM	Verifies that the MDM is present and checks the sensors
Fan	Verifies that the fan is operating correctly

Performing a POST

If you experience errors while operating your autoloader, you may need to reboot the autoloader to perform a POST.

To reboot the SuperLoader 3 autoloader:

- 1 Hold down the power button until the **System Shutdown Please Wait...** message displays.
- 2 Release the power button. The autoloader turns off.
- 3 Press the power button again to turn the autoloader on. POST runs automatically.

Interpreting the POST Results

While the POST is running, a progress indicator showing the name of the test displays on the front panel. If the autoloader is working properly, the message **System Ready** and the current configuration display after the POST completes successfully.

If the autoloader is not working properly, error messages display on the front panel (see [Autoloader Logs](#) on page 104).

Diagnostic Tests from the Front Panel

Diagnostic tests allow you to calibrate parts of the autoloader, check the condition of parts, or test the autoloader's functionality. From the front panel, you can perform all of the diagnostic tests.

Note: Use of the **Diagnostic Commands** from the On-board Remote Management interface should not be issued while the autoloader is being used by host applications. Only use the **Diagnostics Commands** when the autoloader is known to be idle and unavailable to host backup/restore applications.

The autoloader recognizes when the drive or autoloader is executing host commands and will respond appropriately to prevent application failures. A diagnostic command issued between host application commands may not be recognized appropriately, resulting in a failed application.

Because certain tests require you to manually insert a cartridge, you can perform only some of the diagnostic tests using On-board Remote Management (see [On-board Remote Management Diagnostic Tests](#) on page 84).

Note: On-board Remote Management allows you to request all diagnostic tests, but any tests that require a cartridge to be inserted will time-out unless someone manually inserts the cartridge at the appropriate time.

Setting the Security

When you enable the security function, the diagnostic tests are password protected to ensure data integrity. To access any of the diagnostic tests, you must first enter an **Administrator** password. If you do not enter the password, you will be prompted to enter the password when you attempt to perform a diagnostic test.

To enter an **Administrator** password:

- 1 From any menu, click the **Commands** heading. The **Commands** screen displays.
- 2 On the **Command** sub-menu, scroll to **Enter Password**, and then press **Enter**.
- 3 On the **Enter Password** sub-menu, scroll to **Administrator**, and then press **Enter**.

The **Login** screen displays with a row of asterisks. A text box displays above the first asterisk.

- 4 In the textbox, scroll to the first number of the password, and then press **Enter**. The text box above the asterisk disappears and another text box displays above the next asterisk.
- 5 Repeat [Step 4](#) to enter the remaining numbers of your password.

Note: Press **Escape** to backspace to a previous text box, if necessary.

When you have finished entering your password, **Submit Password** displays on the LCD below the asterisks.

- 6 Press **Enter** to submit your password. The display returns to the **Enter Password** sub-menu.

Stopping a Diagnostic Test

At times you may need to stop a diagnostic test while it is in progress. Certain diagnostic tests even require you to stop them or they run continuously. To stop a diagnostic test while it is running, use the **Halt Test** function. When you select **Halt Test**, any picker or magazine functions complete, and then the diagnostic test is stopped.

To perform a **Halt Test** from the front panel:

- 1 While the diagnostic test you wish to stop is running, press **Escape**. The **Diagnostics** sub-menu displays.

- 2 On the sub-menu, scroll to **Halt Test**, and then press **Enter**. **User Abort** displays.
- 3 Press **Enter** to return to the **Diagnostics** sub-menu. Refer to On-board Remote Management for any test results.

To perform a **Halt Test** from On-board Remote Management:

- 1 Select **Halt Test** from the **Diagnostics** drop-down menu, and click **Stop Test**.
- 2 Select **View Status** to see the results of the command. **Test Stopped** displays along with any test results.

Front Panel Diagnostic Tests

You can perform the following using the front panel:

- Tape Alert Logs
- End Curr. Test
- Picker Test
- Magazine Test
- Inventory Test
- Random Moves Test
- Last Test Log

To perform any of the front panel diagnostic tests:

- 1 From the main menu, scroll to **Diagnostics** and press **Enter**.
- 2 Scroll to the test that you want to run and press **Enter**.

If you are already logged in as **Administrator**, the test begins executing immediately. The message **Running Test** displays while the test is in progress.

When the test completes, either the message **Test Successful** displays or the message **Test Failed** and an error code displays. Proceed to [Step 4](#).

Note: Each test takes from 30 seconds to several minutes to complete. To stop the test prematurely, see [Stopping a Diagnostic Test](#) on page 82.

- 3 If you are not logged in, you will be asked to enter the **Administrator** password. Do the following:
 - a From the front panel, enter the **Administrator** password by using the **Up** and **Down** scroll arrows to select each digit, and then press **Enter** to move to the next digit. To move to the previous digit, press **Escape**. When you have entered the entire six digit password, you will be asked to press **Enter** one more time to submit the password. If the password is incorrect, you will be asked to re-enter it using the same procedure. Otherwise, you will be returned to the **Diagnostics** menu. Press **Enter** to run the desired test.

The message **Running Test** displays while the test is in progress. To stop the test prematurely, see [Stopping a Diagnostic Test](#).
 - b When the test completes, either the message **Test Successful** displays or the message **Test Failed** and an error code display.
- 4 If the test is successful, press **Enter** to return to the **Diagnostics** test menu. For detailed results of a test, use On-board Remote Management to retrieve the diagnostic test status (see [Diagnostics Using On-board Remote Management](#)).

On-board Remote Management Diagnostic Tests

You can perform the following diagnostic tests from On-board Remote Management:

- Loader—Picker Test
- Loader—Magazine Test
- Loader—Inventory Test
- Random Moves

Note: On-board Remote Management allows you to request all diagnostic tests, but any tests that require a cartridge to be inserted will time out unless someone manually inserts the cartridge at the appropriate time.

Diagnostics Using On-board Remote Management

To perform diagnostic tests using On-board Remote Management:

- 1 Open a Web browser and connect to the autoloader. The On-board Remote Management main menu displays.
- 2 Click the **Diagnostics** heading. A login window displays.
- 3 Type an **Administrator** user name and a password, and then click **Enter**. The **Diagnostics** sub-menu displays.
- 4 Select the test you wish to perform from the **Diagnostics** drop-down menu, and then click **Start Test**.

The selected diagnostic test runs. While the test is running, you can view the status of the test. To view the status, from **View Diagnostic Test Progress**, click **View Status**.

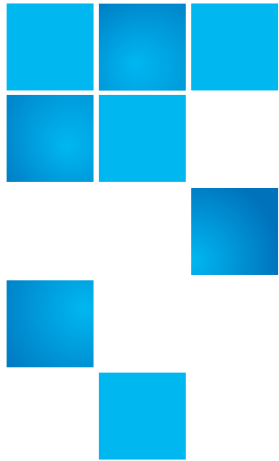

Chapter 7

Customer Replaceable Units (CRUs)

The SuperLoader 3 is not intended for customer servicing. If you do service the unit yourself, the power cable must be removed from the unit and the electrical outlet before removing the cover. Failure to do so may cause severe bodily injury or damage to the equipment.

Some parts of the autoloader are customer-replaceable. Magazines are not interchangeable between the LTO drive types of the SuperLoader 3. These parts can be ordered from Quantum and installed at the site of the unit. Be sure to order the appropriate magazine for your unit.

Customer Replaceable Units (CRUs) include:

- [Replacing a Magazine or Magazine Blank](#)
- [Rack Mounting the Autoloader](#) on page 92

Replacing a Magazine or Magazine Blank

To replace a cartridge magazine or magazine blank, you need to remove the current magazine or blank, and then install the new magazine or blank. If you currently have a magazine blank and wish to change it to a cartridge magazine, you must remove the blank first, and then insert a cartridge magazine. This allows for up a maximum of 16 cartridges in the autoloader, plus one cartridge in the drive.

Note: Handles are either right or left. They are not interchangeable between the left and right sides of the autoloader.

Removing a Magazine

In most cases, you will remove a magazine by using the **Eject** command on the front panel menu. If you need to remove the magazine when the autoloader is powered off, you must remove it manually. Please contact Customer Support for more information.

Removing a magazine using the front panel

- 1 On the menu, scroll to **Commands**.
- 2 Press **Enter**.
- 3 On the **Commands** sub-menu, scroll to **Eject**, and then press **Enter**.
- 4 On the **Eject** sub-menu, scroll to **Right Magazine** or **Left Magazine**, depending on which magazine you want to eject, and then press **Enter**.

The magazine pops forward so that the front of the magazine is no longer flush with the front panel.

- 5 With one hand, grasp the magazine by the handle and slide it forward to remove. Place your other hand under the magazine to support it and prevent it from falling.

Removing a Magazine Blank

Your autoloader comes equipped with either two magazines, or one magazine and one magazine blank. The autoloader will not function without both magazine bays equipped with either a magazine or a magazine blank.

To remove a magazine blank:

- 1 Pull the magazine blank straight out.
- 2 Replace with another magazine blank or a cartridge magazine (see [Reinstalling a Magazine](#)).

Reinstalling a Magazine

To install a cartridge magazine:

- 1 Grasp the magazine by the handle with one hand and support it underneath with the other hand.
- 2 Slide the magazine into the magazine bay. Make sure you position the magazine correctly; it should slide smoothly.

Caution: Insert the magazine slowly to avoid damaging internal components or the autoloader.

- 3 The magazine is correctly installed when you feel it click into place and the front is flush with the front panel.

Installing a Magazine Blank

To install a magazine blank:

- 1 Grasp the magazine blank by the handle with one hand and guide the blank into the magazine bay.
- 2 Slide the magazine blank into the magazine bay until it stops.

Caution: The magazine blank is correctly installed when you feel it click into place and the front of the blank is flush with the front panel of the autoloader.

Changing the Orientation

A magazine or magazine blank can be configured to fit in the right or left magazine bay. The handle must be removed and the appropriate handle attached to match the orientation of the magazine or blank.

To remove and attach a magazine handle, you will need a #1 Phillips screwdriver.

Figure 8 Left Magazine

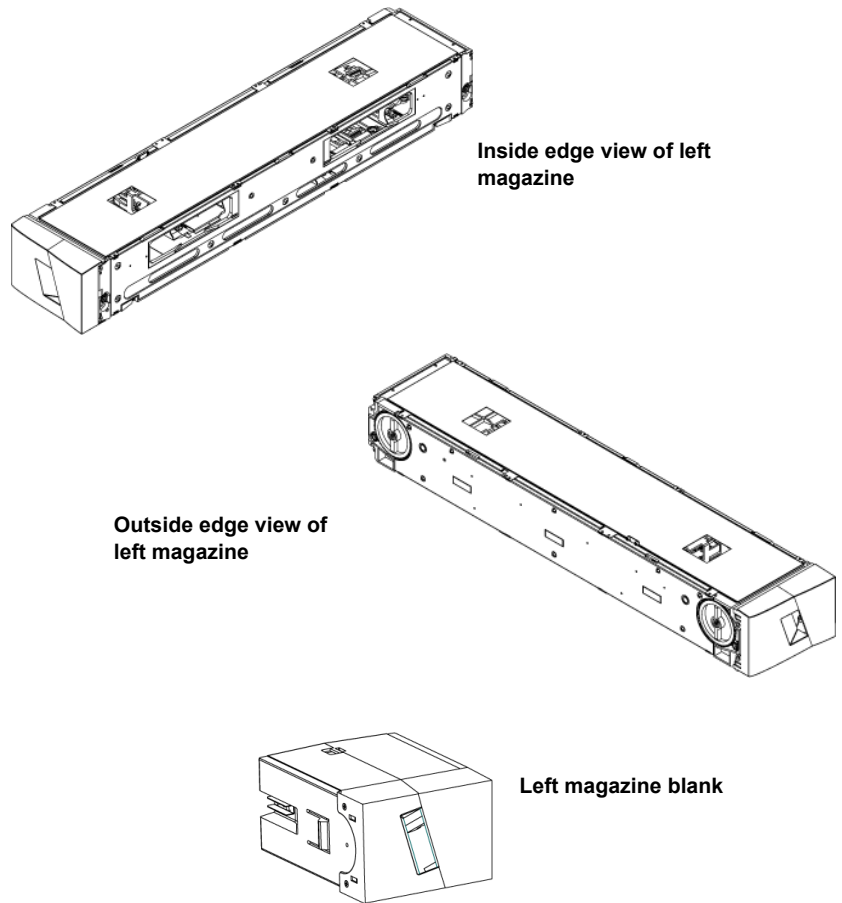

Changing the orientation of a magazine

- 1 Remove the two screws that attach the handle to the front of the magazine.

Figure 9 Removing the Screws from the Handle

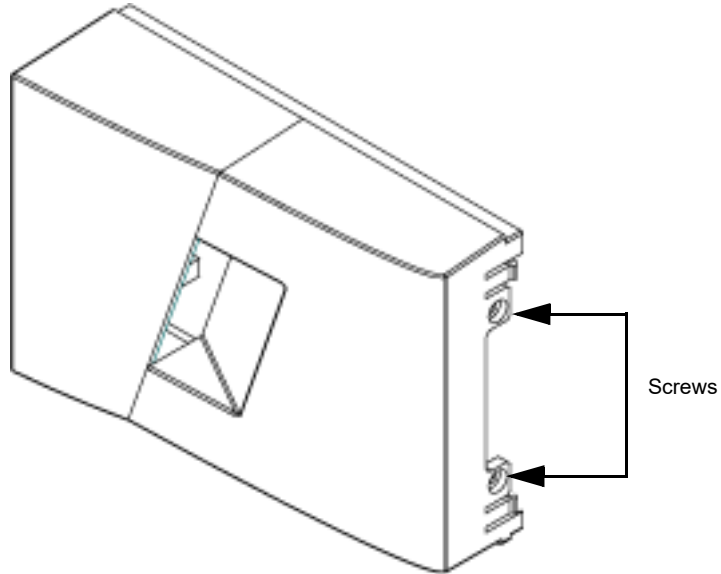

- 2 Unsnap the handle carefully, being careful not to break the hinge.
- 3 Rotate the magazine 180 degrees so that what was the front of the magazine is now the back.
- 4 Attach the appropriate left or right handle to the front of the rotated magazine.
- 5 Snap the handle back onto the front of the magazine.
- 6 Install the two screws to attach the handle securely to the magazine.

Changing the orientation of a magazine blank

- 1 Remove the two screws that attach the handle to the front of the magazine blank.
- 2 Unsnap the handle carefully, being careful not to break the hinge.
- 3 Rotate the magazine blank 180 degrees so that what was the front of the magazine is now the back.
- 4 Add the appropriate right or left handle to the front of the rotated magazine blank.
- 5 Snap the handle back on the front of the magazine blank.

- 6 Install the two screws to attach the handle securely to the magazine blank.

Rack Mounting the Autoloader

The autoloader can be rack mounted directly to the stationary cabinet rails.

Figure 10 Clearance
Requirements for Rack
Mounting

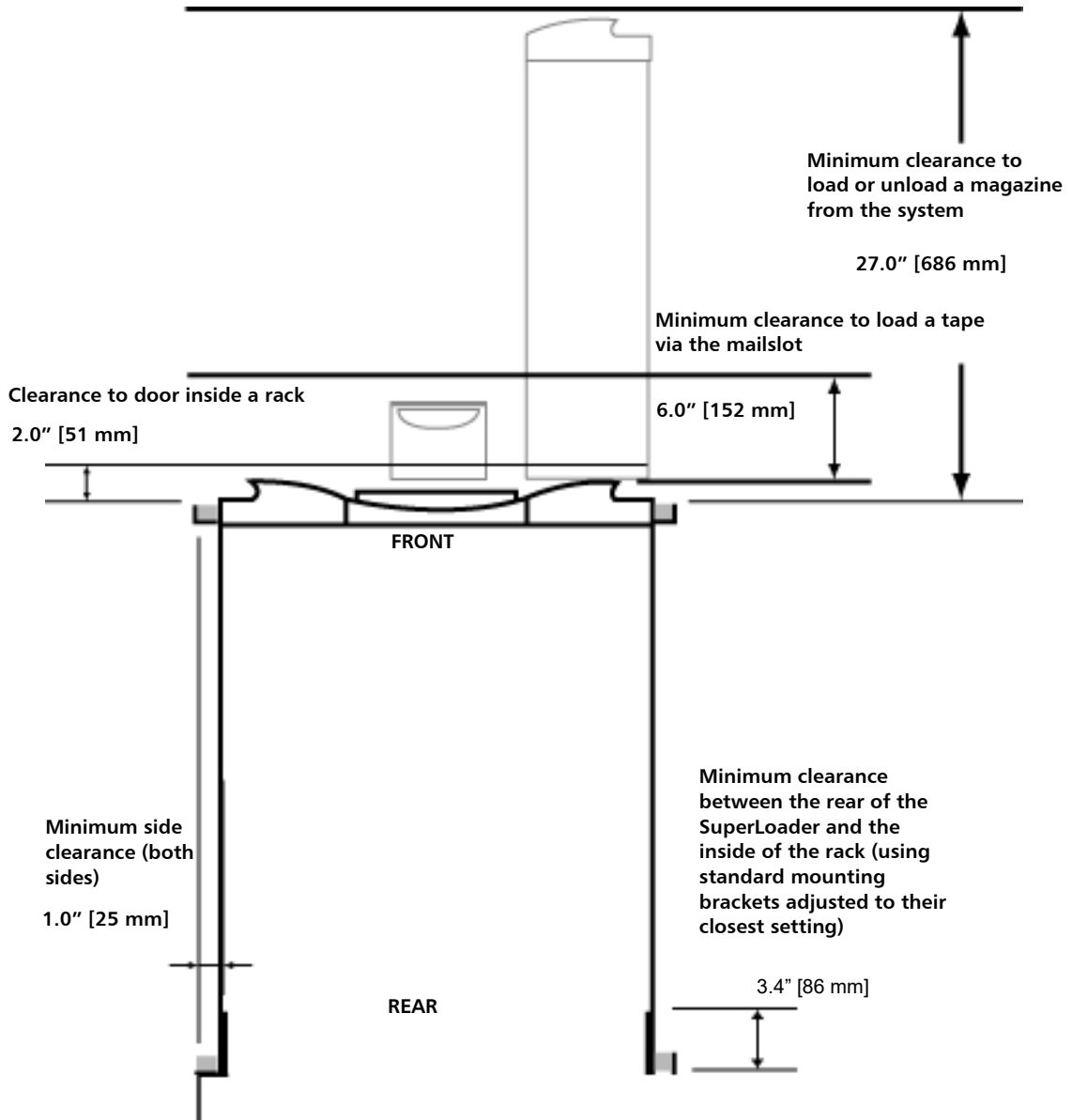

General Preparation for Rack Mount Installation

Take the following general safety steps before beginning a rack mount installation.

- 1 Lower the cabinet feet.
- 2 Extend the cabinet anti-tip device, if available.
- 3 Ensure that the cabinet and all rack mounted equipment have a reliable ground connection.
- 4 Verify that the total current of all rack mounted components (including the SuperLoader) will not exceed the current rating of the power distribution unit or outlet receptacles.
- 5 Secure the help of at least one other person. At least two people are required to safely install the SuperLoader into a rack cabinet.

WARNING: Failure to take these safety steps may result in personal injury or equipment damage.

Caution: Do not remove the top cover of the autoloader during the installation process. Removing the top cover could result in damage to the autoloader.

Stationary Rack Mount Installation

This section describes the steps for attaching the autoloader directly to the stationary rails of a rack.

- 1 Make sure you have the following tools and parts:
 - #2 Phillips screwdriver
 - Level
 - The following autoloader accessory kit parts (see [figure 11](#)):
 - Four autoloader brackets (two long and two short to accommodate different rack depths)
Use the short autoloader brackets (74-60604-03) unless the distance from the front mounting rail to the rear mounting rail is less than 30.25 in. (76.84 cm).
 - Two support brackets (74-60605-01)

- Eight 10-32 x 1/4 inch button head screws for the support brackets (four per support bracket)
- The following parts shipped with your rack and are not supplied by Quantum:
 - Eight clip nuts
 - Eight screws

Figure 11 Required Parts for Installation

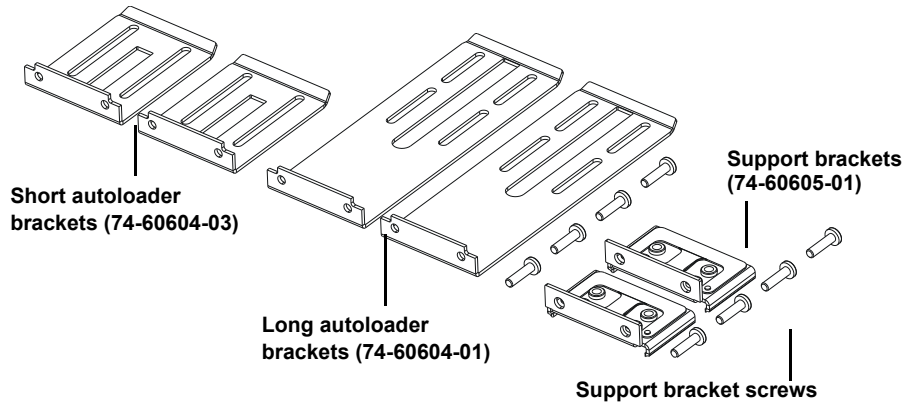

- 2 Install two clip nuts, 1.75 in. (44.45 mm) apart, onto each of the four rails of the rack, making sure that you install each pair of clip nuts at exactly the same level (see [figure 12](#)).

Figure 12 Installing Two Clip Nuts

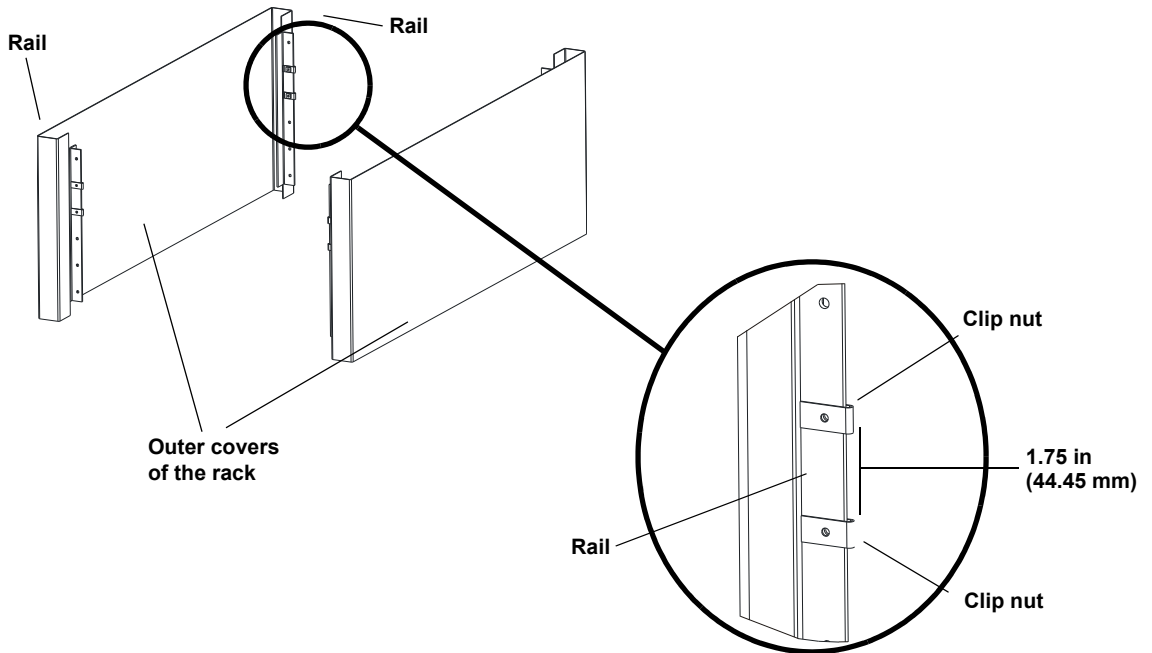

- 3 Select the long or short autoloader brackets (depending on the depth of the rack), and then attach them to the rear of the autoloader (see [figure 13](#)).

Figure 13 Attaching
Autoloader Brackets

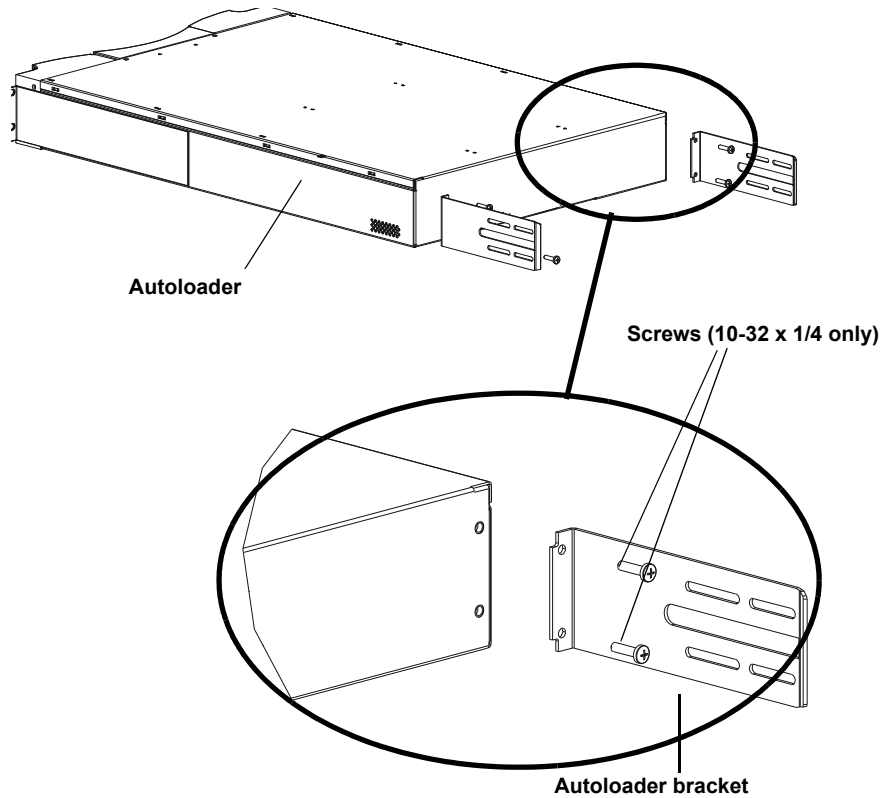

- 4 Using rack screws, attach a support bracket to the clip nuts on each rear rail (see [figure 14.](#))

Note: Be sure to attach the support brackets correctly; the side of the bracket with only two holes should be secured to the rail.

Tighten the screws just enough to hold the support brackets firmly against the rail while still allowing the support bracket to be slightly shifted by hand. This shifting will help facilitate the engagement of autoloader brackets as the autoloader is installed in the rack. You will fully tighten the screws in [Step 8.](#)

Figure 14 Attaching Support
Brackets

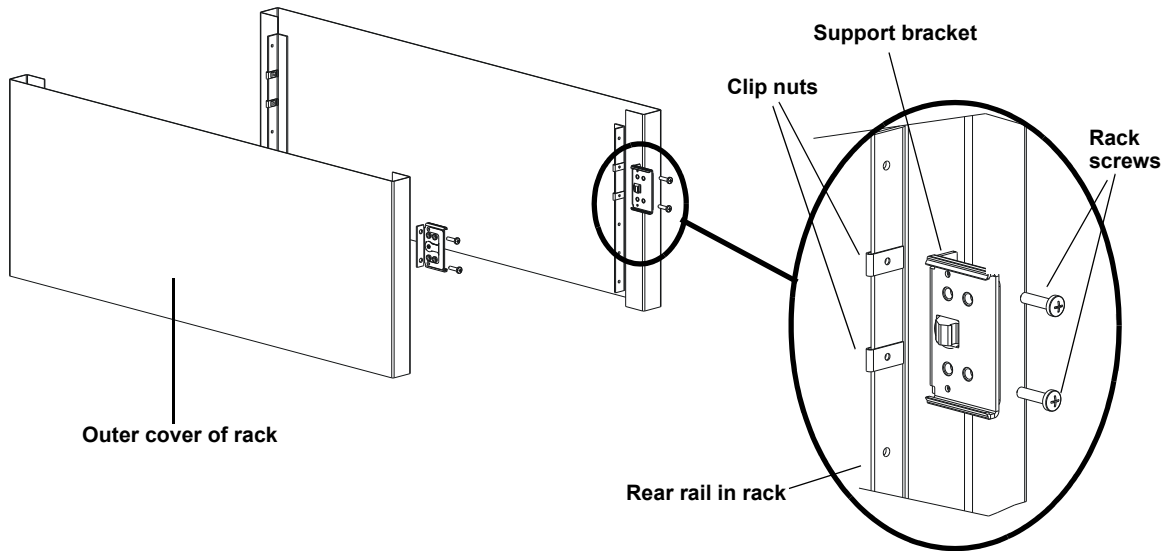

- 5 With the help of a second installer, insert the autoloader into the rack so that the autoloader brackets slide into corresponding support brackets on the rear rails and the tabs at the front of the autoloader align flush with the clip nuts on the front rails (see [figure 15](#)).

Caution: Do not release the front end of the autoloader until it can be secured to the rack.

Figure 15 Sliding Autoloader into Rack

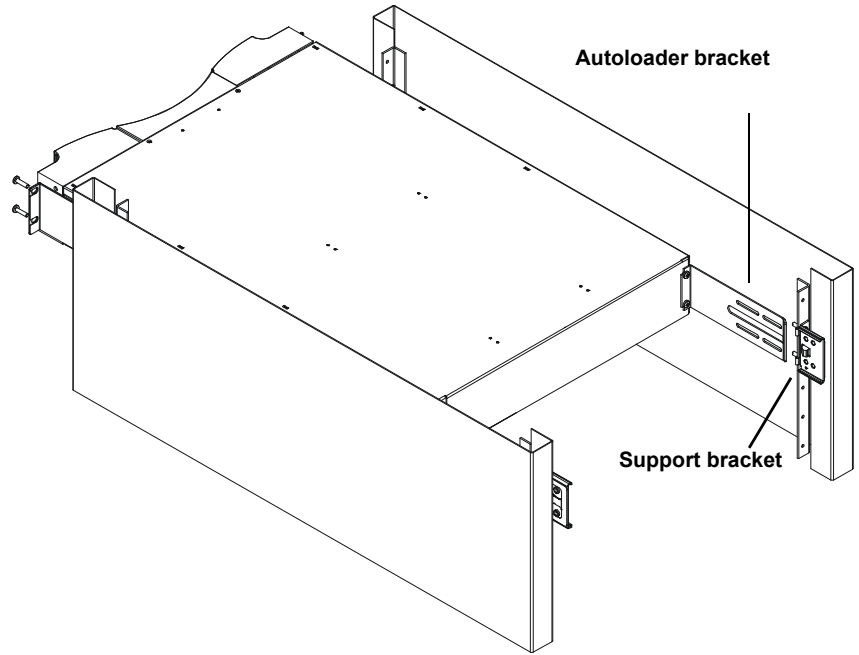

- 6 While the other installer holds the front end of the autoloader, secure the autoloader in the rack by doing the following:
 - a Secure the front end of the autoloader to the rack using four rack screws (two per tab) as shown in [figure 16](#). Tighten the screws just enough to secure the autoloader to the front rails.

Figure 16 Front Alignment

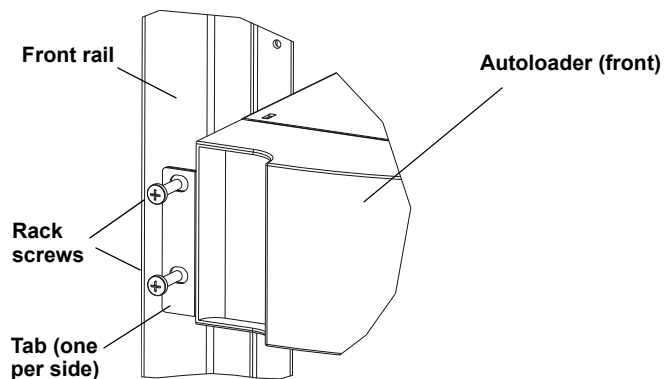

- b Install four screws (two per side) to secure the support brackets to the autoloader brackets (see [figure 17](#)).

Figure 17 Connecting Support Brackets

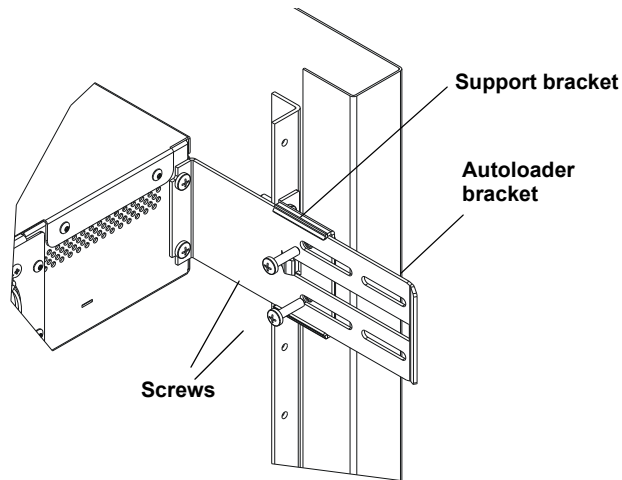

- 7 Verify that the autoloader is level. Adjust as needed.
- 8 When the autoloader is level, tighten all screws securing the autoloader to the rack. This includes the following:
- Four screws securing the autoloader tabs to the front rails.
 - Four screws securing the support brackets to the rear rails.
 - Four screws securing the autoloader brackets to the support brackets.



Chapter 8

Logs and Troubleshooting

This chapter covers information about logs and troubleshooting of the autoloader. The following topics are available:

- [Before Contacting Customer Support](#)
- [Autoloader Logs](#) on page 104
- [Tape Drive Logs](#) on page 116
- [POST Failure Logs](#) on page 118
- [Returning the Autoloader for Service](#) on page 118

Before Contacting Customer Support

Errors that you may experience with your autoloader can range from severe hardware damage to simple connection problems. Before you return your autoloader, you may be able to fix the problem yourself by following some basic troubleshooting procedures.

Other than drive cleaning, there is no recommended routine maintenance for the Quantum SuperLoader 3 autoloader.

The front LCD provides some troubleshooting capabilities, but is limited. On-board Remote Management provides more detailed information

about the present state of the autoloader and past performance, and is more helpful for troubleshooting errors.

[Table 8](#) describes the probable cause and suggested action for problems that you may encounter.

Caution: The SuperLoader 3 is not intended for customer servicing. If you do service the unit yourself, the power cable must be removed from the unit and the electrical outlet before removing the cover. Failure to do so may cause severe bodily injury or damage to the equipment.

Table 8 Probable Cause and Possible Solutions

Problem	Suggested Action
The front panel does not display information.	The connection to the LCD has failed. <ul style="list-style-type: none">• Use On-board Remote Management to troubleshoot error.
The user starts a code update from the front panel without inserting a tape.	<ul style="list-style-type: none">• Power cycle the unit.
The autoloader does not respond on the front panel SCSI bus or Ethernet. Bug checks appear immediately after loading a new version of firmware.	The firmware is corrupted. <ul style="list-style-type: none">• Reload the firmware.
The autoloader is operating slowly.	The autoloader is incorrectly configured for the operating system. <ul style="list-style-type: none">• Go to www.quantum.com for compatibility requirements.
The autoloader does not turn on.	The power cable or source is malfunctioning. The autoloader is incorrectly configured. <ul style="list-style-type: none">• Check all outlets and power cables for proper connection.• Contact customer support.

<p>The front panel and light indicators do not turn on.</p>	<ul style="list-style-type: none"> • Verify that the autoloader is plugged in. • Verify that the power switch on the back is turned on. • Verify that the drive carrier assembly is locked into the autoloader chassis with the four screws supplied. • Contact customer support.
<p>The front panel does not display information, but light indicators above the front panel are turned on.</p>	<ul style="list-style-type: none"> • Connect to the autoloader, using On-board Remote Management with an Ethernet connection and issue a System Reset from the Diagnostics page. • Verify that the drive carrier assembly is locked into the autoloader chassis with the four screws supplied. • On the front panel, press and hold the power switch for 15 seconds, then turn the rear power switch off. Wait 60 seconds and turn the rear power switch back on. • Contact customer support.
<p>The autoloader does not communicate with the host system via the Ethernet.</p>	<ul style="list-style-type: none"> • Verify that the Ethernet cable is connected to the correct hub. • Verify the Ethernet configuration settings via the front panel LCD. If the DHCP server is available, Ethernet status should indicate DHCP, otherwise, you must set a unique IP address and a subnet mask. • Power off the autoloader by turning off the system from the front panel LCD and turning it back on. • Contact customer support.
<p>The application software reports a failure locating a piece of media or fails to move a piece of media as requested.</p>	<ul style="list-style-type: none"> • Use the On-board Remote Management tool and verify that the media is in the expected location internal to the autoloader. • Issue a System Reset either by using On-board Remote Management Diagnostics page System Reset, or by turning the power off from the front panel. • Contact customer support.

The application software reports an error while reading or writing a piece of media.	<ul style="list-style-type: none">• Try a different piece of media.• Issue a System Reset either by using On-board Remote Management Diagnostics page System Reset, or cycle the power from the front panel.• Contact customer support.
Other failures occur.	<ul style="list-style-type: none">• Issue a System Reset either by using On-board Remote Management Diagnostics page System Reset, or cycle the power from the front panel.• Contact customer support.

Autoloader Logs

Whenever any system or application actions occur, the autoloader generates logs recording the action. You can use some of these logs to troubleshoot errors. Errors are problems that occur while operating the autoloader. They prevent the autoloader from completing a specific action.

When an error occurs, one of the following can happen and the system generates a log of the error:

- No error message appears, but the autoloader fails to complete the action.
- An error message appears on the front panel or in the On-board Remote Management screen. The screen displays the error message and the **Hard Log** records non-recoverable errors (see [Hard Logs](#) on page 106).

Note: To troubleshoot hard errors, you may need to power cycle, repair, or replace the unit.

You can use these error logs to determine the type of error, when it occurred, and what parts of the autoloader it affects (or which parts of the autoloader need to be repaired or replaced).

Different types of error logs are generated for the autoloader and the tape drive.

- Autoloader error logs provide information if the errors relate to data cartridge movement.
- Tape drive error logs provide information if the errors relate to the tape drive's read/write performance.

Log Types

While there are other types of logs, use the **Hard Log** to troubleshoot errors. This log helps determine the type of error, time of occurrence, and parts of the autoloader affected.

The autoloader generates the following logs, all with the same basic format (see [Hard Log Example](#) on page 107):

Soft Logs

The **Soft Log** records the autoloader's history during different conditions. It is similar to the **Hard Log** but may have been overwritten by a recovery action.

Update Logs

The **Update Log** records firmware changes and upgrades in the autoloader. It also records information when hardware is updated or changed.

Shadow Logs

(Engineering use only)

Boot Logs

The **Boot Log** keeps track of the boot status in terms of number of hours the unit has been powered on, the number of times the autoloader has been rebooted, and the reason for the reboot.

OEM Logs

OEM Logs store information specific to an OEM.

ID Logs

ID Logs store information specific to an OEM.

Hard Logs

The **Hard Log** is used for troubleshooting purposes and is described in [Retrieving the Hard Log](#). Entries in the **Hard Log** represent errors that were not recovered during normal retry operations.

The following table indicates the ways in which you can retrieve each log type.

Table 9 Log Retrieval Methods

Log Type	http	Front Panel	SCSI
Soft	Yes	Yes	No
Update	Yes	Yes	No
Shadow	Yes	No	No
Boot	Yes	No	No
OEM	Yes	No	Yes
ID	Yes	No	Yes
Hard	Yes	Yes	Yes

Each log records information such as time of the event, error codes, and context information. The key fields are the [Time Stamp](#) on page 108 (in order to correlate the event with a possible application interruption), and the [Error Type](#) on page 110 for which the event was logged.

Retrieving the Hard Log

Partial information from the **Hard Log** can be retrieved from the front panel. The front panel displays only the most important information.

You can retrieve complete **Hard Log** information through On-board Remote Management.

Whenever the autoloader generates a **Hard Log**, On-board Remote Management automatically displays the log information. For front panel retrieval, you must request the information.

By interpreting the information in this log, you can determine how to troubleshoot errors.

To retrieve Hard log information from the front panel:

- 1 From the front panel LCD, scroll to **Diagnostics**, and then press **Enter**. The **Diagnostics** sub-menu displays.
- 2 From the **Diagnostics** sub-menu, scroll to **Error Logs**, and then press **Enter**. The **Error Log** sub-menu displays.
- 3 From the **Error Logs** sub-menu, scroll to **Hard Log**, and then press **Enter**. The log information displays.

To retrieve Hard log information from On-board Remote Management:

- 1 From any screen, click the **Diagnostics** heading. The **Diagnostics** screen displays.
- 2 Click **View Logs**.
- 3 If you want to save logs to your hard drive, click **Save Logs**. If you save a log to a file, you must select a destination folder within 60 seconds.

Hard Log Example

The first line of the **Hard Log** shows the number of entries, queue size, and defines the queue wrap and erase parameters.

The first line of each **Hard Log** event contains the information you are looking for. The highest number entry, shown at the bottom of the queue, contains the most recent event.

You are interested primarily in the time stamp and error fields. Context information followed by the 12 double-words are for engineering use only and cannot be interpreted without firmware source code.

```
**** Hard Log ****
Block 1, 004/016 entries @ 64 bytes each, wrap @ 004, erase
@ 008
0000: 2001-Jun-27, 17:24:06.001, Error: 002f0222, Context:
4802/00000000
        65460621:00610004:ffffffff:ffffffff
        ff741e03:0075ff63:0566063f:007f0000
```

```

          ffffffff:fffffff:fffffff:fffffff
0001: 2001-Jun-27, 17:24:08.036, Error: c02f0223, Context:
4802/00000000
          00000000:00000000:00000000:00000000
          00000000:00000000:00000000:00000000
          00000000:00000000:00000000:00000000
0002: 2001-Jun-27, 17:38:19.777, Error: 002f0222, Context:
4802/00000000
          65460621:00610004:fffffff:fffffff
          ff741e03:0075ff63:0566063f:007f0000
          ffffffff:fffffff:fffffff:fffffff
0003: 2001-Jun-27, 17:38:21.812, Error: c02f0223, Context:
4802/00000000
          00000000:00000000:00000000:00000000
          00000000:00000000:00000000:00000000
          00000000:00000000:00000000:00000000
    
```

Time Stamp

The time the event occurred. This field helps correlate the event with a possible application interruption.

If the unit is unable to acquire the correct time/date from the SNTP time server or the front panel, the time stamp contains values indicating the power cycle number and the time an entry was written relative to that power cycle, listed as Power On Hours (POH).

Note: The unit has no internal real-time clock and requires you to set the time of day from the front panel or the network interface (SNTP).

Error Fields

The error fields are defined as follows:

Bits 31, 30	Bits 29-28	Bits 27-24	Bits 23-20	Bits 19-16	Bits 15-12	Bits 11-8	Bits 7-4	Bits 3-0
Recovery Action	Task ID		Error Type		Context Information			

Recovery Action

Recovery Action defines what the autoloader will do based on the event that occurred.

- If the value is 0, the autoloader continues operations. These events are typically soft recoverable events or events that are just recording an action for when the development team is working on enhancements.
- If the value is nonzero, the autoloader must reboot in order to recover from the event. The reboot happens automatically.

Task ID

Task ID defines what firmware task was being performed at the time of the event.

Task ID	Description
00	System Timer
01	Loader Manager
02	Picker
03	Magazine Left
04	Magazine Right
05	Magazine Up Left
06	Magazine Up Right
07	Drive Manager
08	Bar Code Reader
09	Front Panel
0A	IP
0B	Diagnostic
0C	Error
0D	Code Update

Task ID	Description
0E	ADI
0F	Drive Manager Timer
11	HTTP
12	SNTP
20	Idle
3E	Watch Dog Timer
3F	Un-handle Interrupt

Error Type

Error Type defines the type of error and the action to which the event is related. This field helps identify what caused the event to occur.

Table 10 Error Type Listing and Suggested Actions

Error Type	Description	Suggested Actions
00–25	General Software flags	<ul style="list-style-type: none"> • Check for a Hard Error log. If an error displays in the Hard Error log, power cycle the autoloader. • Check www.quantum.com for firmware updates. • If all previous steps fail, contact customer support.
26	Message Send ID error	<ul style="list-style-type: none"> • Check the SCSI bus cables and terminators. • Check the host adapter. • Power cycle the autoloader. Repeat checks after power cycle. • If all previous steps fail, contact customer support.
27	Message Bad	<ul style="list-style-type: none"> • Check the SCSI bus cables and terminators. • Check the host adapter. • If all previous steps fail, contact customer support.

Error Type	Description	Suggested Actions
28	Message parameter Bad	<ul style="list-style-type: none"> • Check the host device driver. • Check the host application. • Check the SCSI bus cables and terminators. • Check the host adapter. • Power cycle the autoloader. Repeat checks after power cycle. • If all previous steps fail, contact customer support.
29	Invalid Element	<ul style="list-style-type: none"> • Check the host device driver. • Check the host application. • Power cycle the autoloader. Repeat checks after power cycle. • If all previous steps fail, contact customer support.
2A	Invalid Element Status	<ul style="list-style-type: none"> • Check the host device driver. • Check the host application. • Power cycle the autoloader. Repeat checks after power cycle. • If all previous steps fail, contact customer support.
2B–2F	Firmware tables and stacks invalid	<ul style="list-style-type: none"> • Check for a Hard Error log. If an error displays in the Hard Error log, power cycle the autoloader. • Check www.quantum.com for firmware updates.
30	POST Failure	<ul style="list-style-type: none"> • Verify that the magazines are fully seated. • Power cycle. • If all previous steps fail, contact customer support.
31–38	System Monitoring type events	<ul style="list-style-type: none"> • Check for a Hard Error log. If an error displays in the Hard Error log, power cycle the autoloader. • Check www.quantum.com for firmware updates. • If all previous steps fail, contact customer support.

Error Type	Description	Suggested Actions
3A	Drive Error	<ul style="list-style-type: none"> • Check the Drive Log Sense for drive errors. If the drive is still logging errors, contact customer support. • If the drive is logging try a different piece of media. • If the drive fails with two different pieces of media, contact customer support.
3B	Drive Hardware Err	<ul style="list-style-type: none"> • Clean the drive. • Try another piece of media. • If the drive fails with two different pieces of media, contact customer support.
3C	Drive Needs Cleaning	<ul style="list-style-type: none"> • Perform drive cleaning using a valid cleaning cartridge.
3D	Drive Error	<ul style="list-style-type: none"> • Check the Drive Log Sense for drive errors. If the drive is still logging errors, contact customer support. • If the drive is logging try a different piece of media. • If the drive fails with two different pieces of media, contact customer support.
3E	Load Error	<ul style="list-style-type: none"> • Verify that the cartridge does not have labels or other matter anywhere on the cartridge except where labels are expected to be placed. • Try to load a different piece of media. • If multiple pieces of media fail, contact customer support.
3F	Unload Error	<ul style="list-style-type: none"> • Verify that the cartridge does not have labels or other matter anywhere on the cartridge except where labels are expected to be placed. • Try to load a different piece of media. • If multiple pieces of media fail, contact customer support.
49	Offline	<ul style="list-style-type: none"> • No action required.
4A	Door Locked	<ul style="list-style-type: none"> • No action required.

Error Type	Description	Suggested Actions
4B	Open Front	<ul style="list-style-type: none"> • Install the magazine or magazine blank. • Replace the magazine or magazine blank (try a second one if possible). • If all previous steps fail, contact customer support.
4C	Over Temp	<ul style="list-style-type: none"> • Verify that the temperature of the autoloader inlet air is within specifications. • Clear debris from any opening of the autoloader, both in front and in the back. • Verify that both fans are working. If fans are bad, contact customer support.
60–69	Internal communications events	<ul style="list-style-type: none"> • Power cycle. • If the previous step fails, contact customer support.
A0–A4	Picker Servo Errors	<ul style="list-style-type: none"> • If repeated events appear in the Hard Errors log, power cycle the autoloader. Repeat test after power cycle. • If all previous steps fail, contact customer support.
A5	Source Element Empty	<ul style="list-style-type: none"> • Verify that the expected source really does have a cartridge. • If the source is a magazine, replace the cartridge in that slot with a different cartridge and try again. If error continues, replace the magazine. • If source is the tape drive, verify the tape drive has a cartridge and it was ejected. • Power cycle the autoloader. • If the error continues, contact customer support.
A6	Source Magazine Missing	<ul style="list-style-type: none"> • Verify that the magazine is installed correctly into the autoloader. • Remove and reinsert the magazine again. • Try a second magazine, if possible. • Power cycle the autoloader. • If the error continues, contact customer support.

Error Type	Description	Suggested Actions
A7	Mailslot full	<ul style="list-style-type: none"> • Verify that the magazine is installed correctly in the autoloader. • Remove and reinsert the magazine again. • Try a second magazine, if possible. • Power cycle the autoloader. • If all previous steps fail, contact customer support.
A8	Destination Element Full	<ul style="list-style-type: none"> • Verify the expected destination really does not have a cartridge. • If destination is a magazine, install and remove a cartridge from the selected slot and try again. If error continues, replace the magazine. • If destination is the tape drive, verify the tape drive does not have a cartridge. • Power cycle the autoloader. • If error continues, contact customer support. • If the cartridge is in the mailslot opening, remove it. • Verify that the mailslot is fully closed. • Verify that there is no debris in the mailslot opening.
A9	Picker Full	<ul style="list-style-type: none"> • Look in the front of the autoloader and confirm that the picker is full. • Contact customer support.
AA	Picker Cartridge Sensor Error	<ul style="list-style-type: none"> • Look in the front of the autoloader and confirm the picker is full. • Contact customer support.
AB	Drive Path Sensor Error	<ul style="list-style-type: none"> • Power cycle the autoloader. • Contact customer support.
AC	Mail Slot Door Sensor Error	<ul style="list-style-type: none"> • Insert a cartridge into the autoloader via the mailslot. • Power cycle the autoloader. • If all previous steps fail, contact customer support.

Error Type	Description	Suggested Actions
AD	Mail Slot Solenoid Error	<ul style="list-style-type: none"> • Insert a cartridge into the autoloader via the mailslot. • Power cycle the autoloader. • If all previous steps fail, contact customer support.
AE	Unknown Servo Error	<ul style="list-style-type: none"> • Contact customer support.
AF	Error Log Information Event	<ul style="list-style-type: none"> • No action required.
B0–BF	Error Events related to the picker not rotating or translating properly	<ul style="list-style-type: none"> • Power cycle the autoloader. • Contact customer support.
C0	Unknown Motor Error	<ul style="list-style-type: none"> • Power cycle the autoloader. • Contact customer support.
D0	Magazine Solenoid Bad	<ul style="list-style-type: none"> • Check the Task ID in the Hard Error log to determine if the problem is the right or the left magazine. • Remove and reinsert the magazine. Verify that the magazine slides freely, and clicks and locks into place. • Power cycle the autoloader. • Try a different magazine. • If all previous steps fail, contact customer support.
D1	Magazine Present Sensor Bad	<ul style="list-style-type: none"> • Check the Task ID in the Hard Error log to determine if the problem is the right or the left magazine. • Remove and reinsert the magazine. • Power cycle the autoloader. • Make sure that the sensor is not blocked by debris. • If all previous steps fail, contact customer support.
D2–D4	Position Sensor Bad	<ul style="list-style-type: none"> • Check the Task ID in the Hard Error log to determine if the problem is the right or the left magazine. • Remove and reinsert the magazine. • Try a different magazine, if possible. • Power cycle the autoloader. • If all previous steps fail, contact customer support.

Error Type	Description	Suggested Actions
D5-DE	Cartridge flags located on the magazine may be bad or the sensor to detect the flags may have a problem.	<ul style="list-style-type: none">• Check the Task ID in the Hard Error log to determine if the problem is the right or the left magazine.• Remove and reinsert the magazine.• Try a different magazine, if possible.• Make sure that the sensor is not blocked by debris.• Power cycle the autoloader.• If all previous steps fail, contact customer support
DF	Jammed Cartridge	<ul style="list-style-type: none">• Check the Task ID in the Hard Error log to determine if the problem is the right or the left magazine.• Power cycle the autoloader.• Disconnect all data cables from the autoloader.• Power cycle the autoloader.• Use the following OCP commands:<ul style="list-style-type: none">• Commands• Eject• Tape - Mailslot• From Drive• If all previous steps fail, contact customer support

Context Information

Context Information followed by the 12 double-words are for engineering use only and cannot be interpreted without firmware source code.

Tape Drive Logs

- The tape drive generates six types of logs (see [Tape Drive Error Logs](#) on page 137). For troubleshooting errors, you will only use SCSI Check Condition Error logs, Bugcheck Error logs, and Event Error logs.
- [SCSI Check Condition Error Logs](#) on page 138

- [Bugcheck Error Logs \(SDLT 600 only\)](#) on page 141
- [Event Error Logs \(SDLT 600 only\)](#) on page 143

Log Fields

The logs contain three main fields:

Table 11 Log Field Descriptions

Field	Description
Event Log Number	A sequence number that indicates the order in which the event was logged.
Event Number or Name	This field appears in every event log, but varies depending on the event type. This field indicates the type of log.
POH/PC	<p>The tracking information for how many power-on-hours (POH) the drive has had since it was shipped. This is how many hours the drive has had power applied regardless of the number of times it is turned on and off. POH is updated once every 60 minutes the drive has had power applied with no interruptions.</p> <p>Power cycles (PC) is how many times the drive has experienced a POC. Each time a drive logs a Hard Event, it will increment this count as well.</p>

POST Failure Logs

These events indicate that the autoloader or tape drive detected a failure when power was applied. POST may have failed during a reset and retry.

Note: This event type only indicates each time the test ran and experienced the error condition.

Figure 18 POST Failures Event Log Sample

```
                Last fail
Event Log # 4 - PO / ST Error - Last Fail: 88021950 POH / PC = 527 / 71
70000000 00000000 00000000 00000000 00000000 00000000 00000000 00000000
00000000 00000000 00000000 00000000 00000000 00000000 00000000 00000000
```

Table 12 POST Failure Specific Fields

Field	Description
Last Fail	The type of failure that was experienced.

Returning the Autoloader for Service

If you need to return the autoloader to the factory for service, first verify which customer replaceable unit (CRU) that you need to return and return only that CRU, not the entire autoloader.

Once you determine the CRU to replace, contact customer support to obtain return material authorization (RMA) and shipping information. When you have the RMA number, use the following procedure.

Preparing the Autoloader for Shipment

If you must return the complete autoloader for service, use these steps to prepare the autoloader for shipment.

- 1 Remove all cartridges from the unit.
- 2 Power off the autoloader via the front panel.
- 3 Remove the power, Ethernet, and SCSI cables, and any terminators from the autoloader.

Note: Do not ship these items if you are returning the autoloader to the factory.

Removing the Autoloader from a Rack

To remove the autoloader from a rack:

- 1 Loosen the four screws that connect the two support brackets to the two autoloader brackets.
- 2 Loosen the four screws on the front of the autoloader that attach the two front tabs (support brackets) to the front rails. Do not remove the screws completely at this time.
- 3 Remove the four screws at the back of the autoloader that connect the support brackets (two screws per bracket) to the autoloader brackets.
- 4 While supporting the front of the autoloader, remove the four front screws.

WARNING: Injury may occur if the unit is not supported when you remove the front screws. The screws are holding up the front of the unit.

- 5 Using two people, or an appropriately rated mechanical lift, remove the autoloader from the rack by sliding the autoloader out and supporting it from the bottom. The person handling the back of the unit must depress the locking tab on the support bracket while sliding the unit forward.

- 6 Loosen the four screws and remove the autoloader brackets from the back of the autoloader.
- 7 Place the autoloader into the original packaging box. If you no longer have the original packaging, contact your service representative to purchase the packaging kit.

Packing the Autoloader

Use the original packing material to pack the autoloader: the shipping container, two foam insert packing pieces, the accessory kit box (or the filler tube if your autoloader did not come with an accessory kit box), and the anti-static bag. You will also need packing tape.

- 1 Place the anti-static bag over the autoloader.
- 2 Place one of the foam endcaps onto one side of the autoloader. Place the second foam insert onto the other side of the autoloader and make sure the pieces fit snugly onto the autoloader.

Note: One end of the foam insert has a curved piece. This end of the foam insert is designed to fit the front of the autoloader.

- 3 Place the autoloader down into the shipping box and push the back of the autoloader towards the back end of the box.
- 4 Insert the empty accessory kit box (or filler tube) into the shipping box at the front end of the autoloader in the space between the autoloader foam inserts and the shipping container.
- 5 Place any necessary paperwork on top of the autoloader inside the box.
- 6 Close and seal the box.
- 7 Place the shipping label on the box.
- 8 Ship the box.



Appendix A

Specifications

This appendix describes the [Autoloader Specifications](#) relating to the SuperLoader 3 equipped with one of the following drives:

- [LTO-4 and LTO-4 \(Model C\) Drive Specifications](#)
- [LTO-5 and LTO-5 \(Model C\) Drive Specifications](#)
- [LTO-6 and LTO-6 \(Model C\) Drive Specifications](#)
- [LTO-7 Drive Specifications](#)
- [LTO-8 Drive Specifications](#)
- [LTO-9 Drive Specifications](#)

Autoloader Specifications

Rack Mount	
Height	8.9 cm (3.5 in.)
Width	45 cm (17.7 in.)
Length	75.46 cm (29.71 in.)
Package Weight (without media)	22.7 kg (50 lb.)
Footprint	0.32 square meters (3.4 square feet)

Autoloader Performance Specifications

<p>Maximum data transfer rate</p>	<p>LTO-4 Drive Native: 432 GB/hr. Compressed: 864 GB/hr. (assuming 2:1 compression ratio)</p> <p>LTO-5 Drive Native: 500 GB/hr. Compressed: 1 TB/hr. (assuming 2:1 compression ratio)</p> <p>LTO-6 Drive Native: 576 GB/hr. Compressed: 1.44 TB/hr. (assuming 2.5:1 compression ratio)</p> <p>LTO-7 Drive Native: 1080 GB/hr. Compressed: 2.16 TB/hr. (assuming 2.5:1 compression ratio)</p> <p>LTO-8 Drive Native: 1.2 TB/hr. Compressed: 3.0 TB/hr. (assuming 2.5:1 compression ratio)</p> <p>LTO-9 Drive Native: 1.2 TB/hr. Compressed: 3.2 TB/hr. (assuming 2.5:1 compression ratio)</p>
<p>Drive Type (only one type per unit, not interchangeable)</p>	<p>1 LTO-4 drive 1 LTO-5 drive 1 LTO-6 drive 1 LTO-7 drive 1 LTO-8 drive 1 LTO-9 drive</p>
<p>MCBF</p>	<p>100,000 cycles</p>
<p>Typical cycle time</p>	<p>All Drive Types < 40 seconds. One cycle consists of moving a cartridge from the tape drive to a magazine slot, selecting another magazine slot, and then moving the cartridge back to the tape drive. It does not include the time that the tape drive takes to unload or load/calibrate.</p>

Average load time (after placing cartridge in drive)	<p>LTO-4 Drive (LTO Ultrium 4 cartridge) 62 seconds (to BOT for previously written tape) < 19 seconds (to BOT with new tape)</p> <p>LTO-5 Drive (LTO Ultrium 5 cartridge) 20 seconds (to BOT for previously written tape) < 20 seconds (to BOT with new tape)</p> <p>LTO-6 Drive (LTO Ultrium 6 cartridge) 12 seconds (to BOT for previously written tape) < 12 seconds (to BOT with new tape)</p> <p>LTO-7 Drive (LTO Ultrium 7 cartridge) 12 seconds (to BOT for previously written tape) < 12 seconds (to BOT with new tape)</p> <p>LTO-8 Drive (LTO Ultrium 8 cartridge) 12 seconds (to BOT for previously written tape) < 12 seconds (to BOT with new tape)</p> <p>LTO-9 Drive (LTO Ultrium 8 cartridge) 17 seconds (to BOT for previously written tape) Up to 2 hours for uncalibrated LTO-9 tape.</p>
Average unload time (from BOT)	<p>LTO-2 Drive = 19 seconds (from BOT)</p> <p>LTO-3 Drive = < 30 seconds (from BOT)</p> <p>LTO-4 Drive = < 19 seconds (from BOT)</p> <p>LTO-5 Drive = < 19 seconds (from BOT)</p> <p>LTO-6 Drive = < 17 seconds (from BOT)</p> <p>LTO-7 Drive = < 20 seconds (from BOT)</p> <p>LTO-8 Drive = < 24 seconds (from BOT)</p> <p>LTO-9 Drive = < 28 seconds (from BOT)</p>

Autoloader Environmental Specifications

Temperature Range (Dry Bulb)

Operating	+10° to +35°C
Nonoperating	- 40°C to +65°C

Temperature Variation

Operating	10°C per hour
Nonoperating	20°C per hour

Humidity

Operating	20% to 80% noncondensing
Nonoperating	10% to 90% noncondensing
Gradient	10% per hour without condensation

Wet Bulb

Operating	26°C max
Nonoperating	29°C max

Altitude

Operating	-153 m to 3048 m
Nonoperating	-153 m to 12192 m

Autoloader Power Specifications

Line voltage	All Drive Types 60 Hz system: 90–265 VAC 50 Hz system: 90–265 VAC
--------------	---

Maximum power	All Drive Types 160W
Line frequency	All Drive Types 47–63 Hz
AC Input current	All Drive Types 60 Hz system: 4.0 A (RMS) for 115 VAC 50 Hz system: 2.0 A (RMS) for 230 VAC

Autoloader Vibration Specifications

Operating	
Swept Sine Vibration	5–500 Hz, 0.25 G, 0.254 mm (0.01 in.) to smooth crossover, 1 8ve/min, (X, Y, Z) axes
Random Vibration	0.25 Grms, 5–500 Hz (X, Y, Z) axes
Non-Operating	
Swept Sine Vibration	5–500 Hz, 0.75 G, 0.52 mm (0.02 in.) to smooth crossover, 1 8ve/min, (X, Y, Z) axes
Random Vibration	1.06 Grms, 5–500 Hz (X, Y, Z) axes

Autoloader Shock Specifications

Operating	3 G, 5 ms half-sine, 3 pulses (+/-) per axis, X, Y, Z
Non-Operating	20 G, 8 ms half-sine, 3 shocks (+/-) per axis, X, Y, Z

Tape Drive Specifications

The autoloader is equipped with one of the following drive types:

- [LTO-4 and LTO-4 \(Model C\) Drive Specifications](#)
- [LTO-5 and LTO-5 \(Model C\) Drive Specifications](#)
- [LTO-6 and LTO-6 \(Model C\) Drive Specifications](#)
- [LTO-7 Drive Specifications](#)
- [LTO-8 Drive Specifications](#)

- [LTO-9 Drive Specifications](#)

LTO-4 and LTO-4 (Model C) Drive Specifications

Description	Read/write transfer rate: maximum sustained (LTO Ultrium 4 media)	Burst transfer rate	Average access time	Loading time to BOT (for previously written tape)	Unloading time from BOT	Interface type
Quantum LTO-4 (Model C) SAS	Noncompressed mode: 120 MB/s Compressed (2:1 typical): 240 MB/s	320 MB/s (maximum, native)	62 seconds (from BOT)	< 19 seconds	< 19 seconds	Ultra 320 SCSI-3 LVD, or SAS

Media Capacity

Media Type	Capacity
LTO Ultrium 4 storage capacity	12.8 TB with 16 cartridges 25.6 TB (2:1 typical compression) with 16 cartridges

Media Specifications

Characteristic	LTO Ultrium 4
LTO Ultrium 4 formatted capacity	800 GB (noncompressed) 1600 GB (2:1 typical compression)
Basic description	Pre-formatted (servo written) metal particle
Tape length	820 m (2690.2 ft.)
Cartridge dimensions	10.2 x 10.54 x 2.15 cm (4 x 4.15 x .85 in)

Characteristic	LTO Ultrium 4
Read compatibility	LTO Ultrium 2, LTO Ultrium 3, LTO Ultrium 4
Write compatibility	LTO Ultrium 3, LTO Ultrium 4
Shelf life	> 30 years with < 10% loss in demagnetization @ 20°C 40% RH (noncondensing)
Cartridge life	1,000,000 passes (any point on the tape passing the recording head in either direction)
LTO Universal Cleaning cartridge	20 uses

LTO-5 and LTO-5 (Model C) Drive Specifications

Description	Quantum LTO-5	Quantum LTO-5 (Model C)
Read/write transfer rate: maximum sustained (LTO Ultrium 5 media)	Noncompressed mode: 140 MB/s Compressed (2:1 typical): 280 MB/s	Noncompressed mode: 140 MB/s Compressed (2:1 typical): 280 MB/s
Burst transfer rate	500 MB/s (maximum, native)	550 Mb/s (maximum, native)
Average access time	52 seconds (from BOT) for full-height drives 56 seconds (from BOT) for half-height drives	62 seconds (from BOT)
Loading time to BOT (for previously written tape)	< 19 seconds	< 12 seconds
Unloading time from BOT	< 19 seconds	< 17 seconds
Interface type	Serial Attached SCSI (SAS)	SAS

Media Capacity

Media Type	Capacity
LTO Ultrium 5 storage capacity	24 TB with 16 cartridges 48 TB (2:1 typical compression) with 16 cartridges

Media Specifications

Characteristic	LTO Ultrium 5
LTO Ultrium 5 formatted capacity	1500 GB (noncompressed) 3000 GB (2:1 typical compression)
Basic description	Pre-formatted (servo written) metal particle
Tape length	846 m (2775.6 ft)
Cartridge dimensions	10.2 x 10.54 x 2.15 cm (4 x 4.15 x .85 in)
Read compatibility	LTO Ultrium 3, LTO Ultrium 4, and LTO Ultrium 5
Write compatibility	LTO Ultrium 4 and LTO Ultrium 5
Shelf life	> 30 years with < 10% loss in demagnetization @ 20°C 40% RH (noncondensing)
Cartridge life	1,000,000 passes (any point on the tape passing the recording head in either direction)
LTO Universal Cleaning cartridge	50 uses

LTO-6 and LTO-6 (Model C) Drive Specifications

Description	Quantum LTO-6	Quantum LTO-6 (Model C)
Read/write transfer rate: maximum sustained (LTO Ultrium 6 media)	Noncompressed mode: 160 MB/s Compressed (2.5:1 typical): 400 MB/s	Noncompressed mode: 160 MB/s Compressed (2.5:1 typical): 400 MB/s
Burst transfer rate	600 MB/s (maximum, native)	600 MB/s (maximum, native)
Average access time	62 seconds (from BOT) for full-height drives	80 seconds (from BOT) for full-height drives
Loading time to BOT (for previously written tape)	< 12 seconds	< 12 seconds
Unloading time from BOT	< 17 seconds	< 17 seconds
Interface type	Serial Attached SCSI (SAS)	SAS

Media Capacity

Media Type	Capacity
LTO Ultrium 6 storage capacity	64 TB with 16 cartridges 128 TB (2.5:1 typical compression) with 16 cartridges

Media Specifications

Characteristic	LTO Ultrium 6
LTO Ultrium 6 formatted capacity	2500 GB (noncompressed) 6250 GB (2.5:1 typical compression)
Basic description	Dual coat metal particle
Tape length	885 m (2903.5 ft)

Characteristic	LTO Ultrium 6
Cartridge dimensions	10.2 x 10.54 x 2.15 cm (4 x 4.15 x .85 in)
Read compatibility	LTO Ultrium 4, LTO Ultrium 5, and LTO Ultrium 6
Write compatibility	LTO Ultrium 5 and LTO Ultrium 6
Shelf life	> 30 years with < 10% loss in demagnetization @ 20°C 40% RH (noncondensing)
Cartridge life	1,000,000 passes (any point on the tape passing the recording head in either direction)
LTO Universal Cleaning cartridge	50 uses

LTO-7 Drive Specifications

Description	Quantum LTO-7
Read/write transfer rate: maximum sustained (LTO Ultrium 7 media)	Noncompressed mode: 300 MB/s Compressed (2.5:1 typical): 500 MB/s
Burst transfer rate	600 MB/s (maximum, native)
Average access time	60 seconds (from BOT) for half-height drives
Loading time to BOT (for previously written tape)	< 15 seconds
Unloading time from BOT	< 20 seconds
Interface type	Serial Attached SCSI (SAS)

Media Capacity

Media Type	Capacity
LTO Ultrium 7 storage capacity	96 TB with 16 cartridges 240 TB (2.5:1 typical compression) with 16 cartridges

Media Specifications

Characteristic	LTO Ultrium 7
LTO Ultrium 7 formatted capacity	6000 GB (noncompressed) 15000 GB (2.5:1 typical compression)
Basic description	Dual coat metal particle
Tape length	960 m (3149.61 ft)
Cartridge dimensions	10.2 x 10.54 x 2.15 cm (4 x 4.15 x .85 in)
Read compatibility	LTO Ultrium 5 and LTO Ultrium 6
Write compatibility	LTO Ultrium 6
Shelf life	> 30 years with < 10% loss in demagnetization @ 20°C 40% RH (noncondensing)
Cartridge life	1,000,000 passes (any point on the tape passing the recording head in either direction)
LTO Universal Cleaning cartridge	50 uses

LTO-8 Drive Specifications

Description	Quantum LTO-8
Read/write transfer rate: maximum sustained (LTO Ultrium 8 media)	Noncompressed mode: 300 MB/s Compressed (2.5:1 typical): 500 MB/s
Burst transfer rate	600 MB/s (maximum, native)
Average access time	60 seconds (from BOT) for half-height drives
Loading time to BOT (for previously written tape)	< 15 seconds
Unloading time from BOT	< 20 seconds
Interface type	Serial Attached SCSI (SAS)

Media Capacity

Media Type	Capacity
LTO Ultrium 8 storage capacity	192 TB with 16 cartridges 448 TB (2.5:1 typical compression) with 16 cartridges

Media Specifications

Characteristic	LTO Ultrium 8
LTO Ultrium 8 formatted capacity	12000 GB (noncompressed) 28000 GB (2.5:1 typical compression)
Basic description	Dual coat metal particle
Tape length	960 m (3149.61 ft)
Cartridge dimensions	10.2 x 10.54 x 2.15 cm (4 x 4.15 x .85 in)

Characteristic	LTO Ultrium 8
Read compatibility	LTO Ultrium 7, and LTO Ultrium 8
Write compatibility	LTO Ultrium 7 and LTO Ultrium 8
Shelf life	> 30 years with < 10% loss in demagnetization @ 20°C 40% RH (noncondensing)
Cartridge life	1,000,000 passes (any point on the tape passing the recording head in either direction)
LTO Universal Cleaning cartridge	50 uses

LTO-9 Drive Specifications

Description	Quantum LTO-9
Read/write transfer rate: maximum sustained (LTO Ultrium 9 media)	Noncompressed mode: 300 MB/s Compressed (2.5:1 typical): 900 MB/s
Burst transfer rate	1200 MB/s (maximum, native)
Average access time	60 seconds (from BOT) for half-height drives
Loading time to BOT (for previously calibrated tape)	17 seconds
Loading time to BOT (for uncalibrated tape)	Up to 2 hours
Unloading time from BOT	< 28 seconds
Interface type	Serial Attached SCSI (SAS)

Media Capacity

Media Type	Capacity
LTO Ultrium 9 storage capacity	288 TB with 16 cartridges (noncompressed) 720 TB (2.5:1 typical compression) with 16 cartridges

Media Specifications

Characteristic	LTO Ultrium 9
LTO Ultrium 9 formatted capacity	18 TB (noncompressed) 45 TB (2.5:1 typical compression)
Basic description	Dual coat metal particle
Tape length	1035 m (3395 ft)
Cartridge dimensions	10.2 x 10.54 x 2.15 cm (4 x 4.15 x .85 in)
Read compatibility	LTO Ultrium 9, and LTO Ultrium 8
Write compatibility	LTO Ultrium 9 and LTO Ultrium 8
Shelf life	> 30 years with < 10% loss in demagnetization @ 20°C 40% RH (noncondensing)
Cartridge life	1,000,000 passes (any point on the tape passing the recording head in either direction)
LTO Universal Cleaning cartridge	50 uses



Appendix B

Drive Error Logs

This chapter provides information about the error logs dealing with the tape drive. The following topics are available:

- [Tape Drive Error Logs](#)
- [SCSI Check Condition Error Logs](#) on page 138
- [Bugcheck Error Logs \(SDLT 600 only\)](#) on page 141
- [Event Error Logs \(SDLT 600 only\)](#) on page 143

Tape Drive Error Logs

The tape drive generates six types of logs. For troubleshooting errors, you will only use SCSI Check Condition Error logs, Bugcheck Error logs, and Event Error logs.

Error Log Display

Partial information about tape drive error logs can be retrieved from SCSI. All tape drive error logs contain three main fields: **Event Log Number**, **Event Number or Name**, and **POH/PC**.

Table 13 Error Log Display
Field Descriptions

Field	Description
Event Log Number	A sequence number that indicates the order in which the event was logged.
Event Number or Name	This field appears in every event log, but varies depending on the event type. This field indicates the type of log.
POH/PC	The tracking information for how many power-on-hours (POH) the drive has had since it was shipped. This is how many hours the drive has had power applied regardless of the number of times it is turned on and off. POH is updated once every 60 minutes that the drive has had power applied to it without interruptions. Power cycles (PC) is how many times the drive has experienced a power-on cycle. Each time a drive logs a Hard Event, it will increment this count as well.

In addition to these main fields, each type of log contains specialized fields including [SCSI Check Condition Error Logs](#), [Bugcheck Error Logs \(SDLT 600 only\)](#) on page 141, and [Event Error Logs \(SDLT 600 only\)](#) on page 143.

SCSI Check Condition Error Logs

SCSI Check Condition Error logs record SCSI events that have been sent to the host in response to a command not completing successfully. These logs may be related to the events logged prior to this entry indicating that the event created a check condition that the host should know about.

Table 14 SCSI Check Condition
Error Log Field Descriptions

Field	Description
Media ID (MID)	A Media ID which is an internal identification number, written to the media the first time the media is used, to aid in tracking the media to the different events. This ID does not correlate to any media ID used by application software.

Field	Description
Sense Key	The SCSI equivalent of Sense Key as defined by the SCSI standard.
ASC/ASCQ	The SCSI equivalent of Additional Sense Code (ASC) and Additional Sense Code Qualifier (ASCQ) as defined by the SCSI standard.

Table 15 Sense Key Field Definitions

Sense Key	Definition
0h	No Sense. This is an indicator that the drive did not have an error but that the host system may have sent an incorrect command or that a field in the changing parameters information was not correct. This is also an indicator that a request to move the tape past an EOD or a read of a filemark may have been attempted.
1h	Recovered Error. The drive had a recoverable error. This is one in which the drive detected something that may not be correct, but that the problem would not prevent the drive from functioning correctly. It may be just an indicator of an event that the drive was able to correct. For example, a Cleaning Requested status shows that the drive wants a cleaning tape used, but will still function correctly without it. This sense key will only be recorded in the logs if it is a Cleaning Requested condition.
2h	Not Ready. The drive is not ready for tape functionality. This is not reported in the drive log pages.
3h	Medium Error. The drive was not able to read or write successfully to the tape. Look at the Event Logs and correlate the events with media and system logs to determine if this is due to media or the drive. This sense key is recorded in the drive logs.
4h	Hardware Error. The drive has detected an error condition related to the hardware. You will need to refer to the Sense Key and ASCQ, along with other event logs to best understand the error. Based on the log information, replace the appropriate component. This sense key is logged each time it is reported.
5h	Illegal Request. The requested command had an incorrect parameter defined and you will need to review the actual command and parameter to determine what was wrong. This is not logged in the drive logs.

Sense Key	Definition
6h	Unit Attention. A condition exists that impacts the drive's functionality. Examples include a SCSI Bus reset, or a transition from Ready to Not Ready. A reset is required because Mode Page setting may change after a reset and the host will need to know that. This sense key is not logged in the drive logs.
7h	Data Protected. The media currently in the drive is write-protected. This can be a hardware write protect or software. This sense key is not logged in the drive logs.
8h	Blank Check. While reading, writing, or doing a search on the media that the drive encountered a EOD mark or a long gap was detected. A long gap may be the result of a drive stopping the write command without doing the proper command termination. This sense key is not reported in the drive logs.
Bh	Aborted Command. Command aborted. Generated when the drive aborts a command.
Dh	Volume Overflow. The tape drive has reached the physical EOT and can no longer write data to the tape. This sense key is not reported in the drive logs.
Eh	Miscompare. During the drive self tests, the drive detected a data miscompare while executing the internal test. This error would be an indicator that the drive should be returned for repair.

Table 16 ASC/ASCQ Field Descriptions

ASC/ASCQ	Description	Suggested Action
0C/00	Write Error. Drive was not able to successfully write the customer data to the tape.	<ul style="list-style-type: none"> • Problem may be the tape cartridge or the drive. Check logs to correlate A401/A501 events with media type and ID to the system logs. • If the problem continues, contact customer support.
11/00	Unrecoverable Read Error. After exhausting the read recovery algorithms, the drive was not able to read the data correctly.	<ul style="list-style-type: none"> • Problem may be the tape cartridge or the drive. Check logs to correlate A400/A500 events with media type and ID to the system logs. • If the problem continues, contact customer support.

ASC/ASCQ	Description	Suggested Action
14/00	Entity Not Found. A logical block that was written on the tape was not found while trying to read the data.	<ul style="list-style-type: none"> • Problem may be the tape cartridge or the drive. Check drive logs to correlate events that may have led up to this condition. • If the problem continues, contact customer support.
47/00	SCSI Parity Error. SCSI bus communications problem.	<ul style="list-style-type: none"> • Check SCSI cables, terminators, and all devices attached to the SCSI bus.
80/01	Cleaning Required. The drive has detected a condition in which a cleaning tape must be used. (SDLT)	<ul style="list-style-type: none"> • Use a cleaning tape and/or different media. Check drive logs to review related events. If this persists with multiple media after cleaning, the drive may need to be replaced. If all related to one piece of media, replace that tape cartridge. • If the problem continues, contact customer support.

Bugcheck Error Logs (SDLT 600 only)

Bugcheck Error logs typically indicate that the firmware has reached a point in the decision process that requires a drive reset. There are 11 bugchecks, indicated by the Bugcheck Error field found in the event log's first line. The following conditions may cause a bugcheck:

- Hardware errors
- Media errors
- Power supply problems
- External conditions (shock, vibe, hot, cold, and so on)
- Firmware problems

Note: Typically, firmware problems are not the cause and you should check for other sources. If it is determined to be a firmware issue, contact customer support.

Table 17 Bugcheck Log Field Descriptions

Field	Description
<p>Event Number: The Event Number is one of the common first line fields explained in the Event Types sections. Below is a listing of the Bugchecks for each event number.</p>	
B810	Library Port Communications problems—Library or drive problem. If the problem continues multiple times after you reset the drive, contact customer support.
E204	Unexpected Time 2 Interrupt—Drive problem. If the problem continues multiple times after you reset the drive, contact customer support.
EE01	Spurious Non-Askable Interrupt—Drive problem. If the problem continues multiple times after you reset the drive, contact customer support.
EE02	Spurious Time Interrupt—Drive problem. If the problem continues multiple times after you reset the drive, contact customer support.
EE03	Spurious Level 5 Interrupt—Drive problem. If the problem continues multiple times after you reset the drive, contact customer support.
EE04	Spurious Drive Comm Interrupt—Drive or Loader problem. If the problem continues multiple times after you reset the drive, contact customer support.
EE06	Spurious Diagnostic Comm Interrupt—Drive problem. If the problem continues multiple times after you reset the drive, contact customer support.
EE08	Watch Dog Timer Expired—SCSI bus, host controller, or drive problem. If the problem continues multiple times after you reset the drive, contact customer support.
EE09	Spurious Power Fail—Power supply or power cables problem. If the problem continues multiple times after you reset the drive, contact customer support.
EE0D	Spurious Level 6 Interrupt—Drive problem. If the problem continues multiple times after you reset the drive, contact customer support.
F202	Loader Time-Out—Loader problem. If the problem continues multiple times after you reset the drive, contact customer support.

Event Error Logs (SDLT 600 only)

These logs record basic drive events including drive errors, calibration, and history-related actions. There are 14 event error logs, indicated by the Event number filed, and the Event number is located on the first line. All Event Error logs contain the same specialized fields.

Table 18 Error Event Logs Field Descriptions

Field	Description
V Number	The version of firmware the drive was using when the event was logged.
Date	A reference date for when the firmware was created.
Time Stamp	The total time in which the tape drive has had power applied to the tape drive since the last power cycle. This is hours, minutes, seconds, and milliseconds. There is no date associated with the power-up time.

In addition to the specialized fields, each Event Error log has specific information about the cause and the suggested actions to follow for troubleshooting errors. This information can be found in the block descriptors of each log. To find information on specific Event Error log entries, see:

- [A500: Hard Read Error](#) on page 143
- [A501: SDLT Hard Write Error](#) on page 145
- [A502: SDLT Loader Communication Error](#) on page 147
- [A503: SDLT Drive Servo Error](#) on page 148
- [A507/A508: Directory Read Failure/Directory Write Failure](#) on page 153

A500: Hard Read Error

Hard Read Error is a recorded event indication the tape drive detected a condition in which the drive was not successfully able to read the data from a particular location on the media.

Table 19 Hard Read Error/Hard Write Error Block Descriptor

Long Word	Byte 03	Byte 02	Byte 01	Byte 00
1	Media ID			
2	Physical Block Number (PBN)			
3	Tape Address			
4-12				
13	Media Type		Tape Format	
14			Tape Number	
15	Retry Count	Logical Blk Num (LBN)		
16	Head Wear Hours		BRC Head Wear Hours	

Table 20 Hard Read /Hard Write Error Field Descriptions

Field	Description
Media ID	Random number used to identify tapes
Physical Block Number (PBN)	Physical block location where the error occurred. There is one physical block for each read/write head on each track. For example, if there are four separate heads and 10 tracks, there would be 40 physical blocks on a single point of that media.
Tape Address	Location on tape in inches
Track Number	Track number where error occurred
Retry Count	Retry count used when reading
Logical Block Number (LBN)	A block of data on media that includes all physical block associated with all heads for that single point of media. For example, in the forward direction if there are four heads and 10 tracks, five forward and five backwards, there would be two logical blocks going backwards. Yet these two logical blocks would equate to 10 physical blocks.

Field	Description
Head Wear Hours	Not applicable
BBC Head Wear Hours	Not applicable

Cause

This error could be due to one or more of the following:

- A bad spot on the media
- A failure of the drive to determine the data read from the tape was good due to bad CRC
- Other indicators used by the drive to insure data integrity
- The data originally written was not written correctly

Suggested Actions

Following is a list of suggested actions:

- Verify if multiple events on the same media occur, or multiple events on different media occur. With this information you can determine if the failures is media caused or drive caused.
- Make sure the event is not due to media being written badly by some other drive. To confirm the media was not written incorrectly, look for A401 events with the same media ID on this drive and other drives this media may have been written to.
- If the problem continues, contact customer support.

A501: SDLT Hard Write Error

Write Error is an event is which the tape drive detected a condition that the drive was not successfully able to write data to the media.

Table 21 Hard Read Error/Hard Write Error Block Descriptor

Long Word	Byte 03	Byte 02	Byte 01	Byte 00
-----------	---------	---------	---------	---------

1	Media ID		
2	Physical Block Number (PBN)		
3	Tape Address		
4-12			
13	Media Type		Tape Format
14			Tape Number
15	Retry Count	Logical Blk Num (LBN)	
16	Head Wear Hours		BRC Head Wear Hours

Table 22 Hard Read Error/Hard Write Error Field Descriptions

Field	Description
Media ID	Random number used to identify tapes
Physical Block Number (PBN)	Physical block location where the error occurred. There is one physical block for each read/write head on each track. For example, if there are 4 separate heads and 10 tracks, there would be 40 physical blocks on a single point of that media.
Tape Address	Location on tape in inches
Track Number	Track number where error occurred
Retry Count	Retry count used when reading
Logical Block Number (LBN)	A block of data on media that includes all physical block associated with all heads for that single point of media. For example, in the forward direction if there are 4 heads and 10 tracks 5 forward and 5 backwards, there would be two logical blocks going backwards. Yet these two logical blocks would equate to 10 physical blocks.
Head Wear Hours	Number of Head Wear Hours for the SDLT Head reported by Servo
BBC Head Wear Hours	Number of Head Wear Hours for the BRC Head reported by Servo

Cause

This error could be due to one or more of the following:

- A bad spot on the media
- A failure of the drive to determine the data read from the tape was good due to bad CRC

Suggested Actions

Following is a list of suggested actions:

- Check the Media IDs. Multiple Media IDs may indicate the drive is the problem. Similar media IDs may indicate the media is the problem.
- Use a cleaning tape and try the same media again. Then try different media before indicating the drive as the failure.

Note: If the drive logs this error, the cleaning light may be turned on recommending a cleaning as well.

- Run a Tape Drive Write/Read test with two pieces of media. If test fails, contact customer support.

A502: SDLT Loader Communication Error

Table 23 Loader
Communication Error Block
Description

Long Word	Byte 03	Byte 02	Byte 01	Byte 00
1	Loader Communication Status			

Table 24 Loader
Communication Error Field
Description

Description	Value
Loader Communication Status: Status of communication problem	

Description	Value
Overrun Error	0x10
Parity Error	0x20
Framing Error	0x40

Cause

This error could be due to an internal communication error.

Suggested Actions

Following is a list of suggested actions:

- Power cycle the unit.
- If the problem repeats, perform an SuperLoader Random Access test.
- If problem repeats, contact customer support.

A503: SDLT Drive Servo Error

The Drive Servo Error occurs when the SDLT tape drive experiences Servo errors. These errors will result in Tape Drive Read/Write Errors.

Table 25 Drive Servo Error Block Descriptor

Long Word	Byte 03	Byte 02	Byte 01	Byte 00
1	Log Type			
2				
3	Drive Error Code		Drive Status (MSW)	
4	Drive Status (LSW)			
5			Track Number	
6	Physical Block Number (PBN)			

7-11		
12	Power on Hours (LSW)	Power on Hours (MSW)
13	Head Wear Hours	
14		POST Flags (MSW)
15	POST Flags (LSW)	
16-36		

Table 26 Drive Servo Error Field Descriptions

Field	Description		
	Description	Value	
	Calibration Failure	0x15	
	Drive Command Time Out	0x09	
	Controller to Drive Interface	0x0A	
	Drive Command Time Out	0x21	
	Drive Event	0x20	

Drive Error Code: Error code from Servo processor

	Major Error Code	Description	Possible Action
	0000h-001Fh	Power on Self Test Error	Check Power Check Post Flags
	0020h-003Fh	Initialization Errors	Check Power If Repeating ensure no media loaded No Media and repeat drive replacement

Field	Description		
	0040h-004Fh	Cartridge Insertion Errors	Check Cartridge
	0050-005F	Cartridge Unload Errors	Check Cartridge/Leaders
	0060h-006F	Cartridge Unload Errors	Check Cartridge/Leaders
	0070-007F	Cartridge Extraction Errors	Check Cartridge/Leaders
	0080h-009Fh	Servo Errors	Possible drive, try multiple media
	00A0h-00Afh	Miscellaneous Tape Motion Errors	Possible drive, try multiple media
	00B0h-00BFh	Hardware Errors	Possible Drive
	00C0h-00DFh	Internal Software Errors	Possible drive, try multiple media
	00E0h-00EFh	Interrupt Trap Errors	Possible Drive
	00F0h-00FFh	Miscellaneous Errors	Possible Drive

Drive Status (on Error)

	MSW Bits	Description
	03	15 undefined
	02	Drive did not buckle the tape when loading
	01	Drive is unloading a tape
	00	Drive is loading a tape
	LSW Bits	Description
	15	Drive is running a cleaning tape
	14	Drive is ejecting a cartridge
	13	Drive has No Tape Tension

Field	Description	
	12	Drive is in the Process of Calibration after loading a tape cartridge
	11	Drive is in the Process of Rewinding the tape to BOT
	10	Drive is at a End of Track
	09	Drive is on the Correct Track and physical location of the media
	08	Drive is Moving the Tape and Seeking to a Track location
	07	Drive is Stopped on Tape
	06	Drive is at EOT
	05	Drive is at BOT
	04	Drive is in process of loading the tape step 2
	03	Drive is in process of loading the tape step 1
	02	A cartridge has been inserted
	01	No cartridge has been inserted
	00	Drive is in the Process of Initializing (typical after power on or a total drive reset)
POST Flags	MSW Bits	Description
	15	Unused
	14	Unused
	13	Unused
	12	Unused
	11	Unused
	10	Unused
	09	Unused
	08	Unused
	07	Unused

Field	Description	
	06	Unused
	05	Unused
	04	Unused
	03	Unused
	02	Unused
	01	Unused
	00	EEROM Bad
	LSW Bits	Description
	15	Unused
	14	BOT LED bad
	13	Unused
	12	A to D test failed
	11	Unused
	10	Unused
	09	EEROM check sum failed
	08	12 volts bad
	07	Unused
	06	Unused
	05	PLL clock test failed
	04	EEROM check sum failed
	03	Code check sum failed
	02	RAM test failed

Field	Description		
	01	Address Line test failed	
	00	RAM test failed	

Cause

This error could be due to grave failure to track the optical servo or electrical servo.

Suggested Actions

Run a Tape Drive Write/Read test with two pieces of media. If test fails, contact customer support.

A507/A508: Directory Read Failure/Directory Write Failure

These events indicate a possible problem in reading or writing to the tape directly.

Table 27 Directory Read Failure/Write Failure Block Descriptor

Long Word	Byte 03	Byte 02	Byte 01	Byte 00
1				Called Mode
2	Save Format		New Format	
3	Flags			
4	Read Fail Status	Status	Status 2	EEPROM Status
5				
6	Media ID			

7	CR Message Pointer	
8	Track Size	
9	EOT Status	
10-12		

Table 28 Directory Read/Write Failure Field Descriptions

Field	Description	
Called Mode	Directory mode called from	
	Mode	Value
	READ on LOAD	1
	WRITE on UNLOAD	2
	WRITE from BOT	3
	READ BOTH REVERSE	4
	READ BOTH FORWARD	5
Save Format	Tape format before reading directory	
	Format	Value
	Unknown	0x0000
	Initial	0x0001
New Format	Tape format of the directory.	

Field	Description	
Flags	Directory flags	
	Bits	Description
	14-31	Filler
	13	Calibration On Load success
	12	Lram directory stale
	11	Tape direction rev
	10	Directory stale
	09	Retry needed
	08	Directory clobbered
	07	Non-zero first track
	06	Unknown format
	05	Event log
	04	Format mismatch
	03	Directory Write failed
	02	LBN 0 found
	01	Inhibit directory write
00	Read On Load complete	

Field	Description	
Read Fail Status	Status for Directory Read failures	
	Description	Value
	Unknown	0x0
	Retry failed	0x1
	No Blocks	0x2
	Goofy Blocks	0x3
	No Block 0	0x4
	Bad ECC	0x5
	Directory Cell Recovery	0x6
	Directory Cell stale	0x7
	Directory Cell fail	0x8
	Serpentine	0x9
	Verify fail	0xA
	BOT fail	0xB
	BOT No Blocks	0xC
	BOT Bad ECC	0xD
	Indeterminate Blocks	0xE
Could not correct	0xF	
System Error	0x10	
Calibration failed	0x11	
Drive Error	0x12	

Field	Description	
Status	Media directory status	
	Description	Value
	Directory unknown	0
	No directory	1
	Partial directory	2
	Directory complete	3
	Directory stale	4
EEPROM Status	EEPROM directory status	
	Description	Value
	Directory recovered	1
	Initial	0x0001
	No LBN 0	10
	Media ID mismatch	11
	On Tape directory not empty	12
	Sync Lock mismatch	13
	Directory unreliable	20
Media ID	Media ID from tape	

Field	Description	
EOT Status	Directory status four	
	Description	Value
	Directory recovered	1
	Directory attempt	2
	Bad directory cell structure	10
	Bad directory cell entry	11
	Invalid track	12
	Sync Lock mismatch	20
	Track zero	21
	Directory No Pair	30
	Directory Zeroed	31
	Directory Bad Revision	32
	Directory Bad Media ID	33
	Directory RSTO	34

Cause

This error could be due to one of the following:

- Drive may need to rebuild to directory
- Drive is having difficulty writing to directory

Suggested Actions

Following is a list of suggested actions:

- Check for other Write Errors.
- If the problem continues, contact customer support.

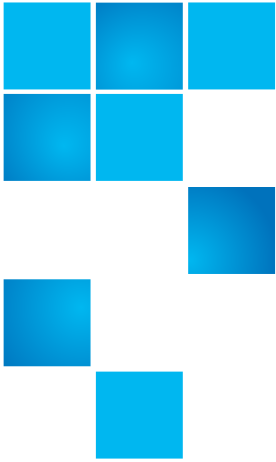

Appendix C

Regulatory Statements

FCC Statement

This equipment has been tested and found to comply with the limits for a Class A digital device, pursuant to Part 15 of the FCC Rules. These limits are designed to provide reasonable protection against harmful interference when the equipment is operated in a commercial environment. This equipment generates, uses, and can radiate radio frequency energy and, if not installed and used in accordance with the instruction manual, may cause harmful interference to radio communications.

Any changes or modifications made to this equipment may void the user's authority to operate this equipment.

Operation of this equipment in a residential area may cause interference in which case the user at his own expense will be required to take whatever measures may be required to correct the interference.

This device complies with Part 15 of the FCC Rules. Operation is subject to the following conditions:

- This device may not cause harmful interference, and
- This device must accept any interference received, including interference that may cause undesired operation.

Taiwan Statement

警告使用者:

這是甲類的資訊產品，在居住的環境中使用時，可能會造成射頻干擾，在這種情況下，使用者會被要求採取某些適當的對策。

Japan Notice

この装置は、情報処理装置等電波障害自主規制協議会（VCCI）の基準に基づくクラスB情報技術装置です。この装置は、家庭環境で使用することを目的としていますが、この装置がラジオやテレビジョン受信機に近接して用されると、受信障害を引き起こすことがあります。

取扱説明書に従って正しい取り扱いをして下さい。

Canadian Notice (Avis Canadien)

This Class A digital apparatus complies with Canadian ICES-003.

Cet appareil numérique de la classe A est conforme à la norme Canadian Notice (Avis Canadien)

This Class A digital apparatus meets all requirements of the Canadian Interference-Causing Equipment Regulations.

Cet appareil numérique de la classe A respecte toutes les exigences du Règlement sur le matériel brouilleur du Canada.

European Union Notice

Products with the CE Marking comply with both the EMC Directive (89/336/EEC) and the Low Voltage Directive (73/23/EEC) and its amendment (93/68/EECD) issued by the Commission of the European Community.

Compliance with these directives implies conformity to the following European Norms (in brackets are the equivalent international standards):

- EN55022 (CISPR 22) - Electromagnetic Interference
- EN50082-1 (IEC801-2, IEC801-3, IEC801-4) - Electromagnetic Immunity
- EN60950 (IEC950) - Product Safety

Product Safety Electrostatic Discharge

To prevent damaging the system, be aware of the precautions you need to follow when setting up the system or handling parts. A discharge of static electricity from a finger or other conductor may damage system boards or other static-sensitive devices. This type of damage may reduce the life expectancy of the device.

To prevent electrostatic damage, observe the following precautions:

- Avoid hand contact by transporting and storing products in static-safe containers.
- Keep electrostatic-sensitive parts in their containers until they arrive at static-free workstations.
- Place parts on a grounded surface before removing them from their containers.

- Avoid touching pins, leads, or circuitry.
- Always be properly grounded when touching a static-sensitive component or assembly.

Grounding Methods

There are several methods for grounding. Use one or more of the following methods when handling or installing electrostatic-sensitive parts:

Use a wrist strap connected by a ground cable to a grounded workstation or computer chassis. Wrist straps are flexible straps with a minimum of 1 mega-ohm 10 percent resistance in the ground cords. To provide proper ground, wear the strap snug against the skin.

Use heel straps, toe straps, or boot straps at standing workstations. Wear the straps on both feet when standing on conductive floors or dissipating floor mats.

Use conductive field service tools.

Environmental Compliance

Quantum is committed to providing quality products in an environmentally sound manner and to comply with all applicable environmental laws, rules and regulations.

This product was designed, manufactured and made available with consideration to worldwide laws, rules and regulations applicable to the product and the electronics industry including the European Union Directives 2002/95/EC & 2002/96/EC (RoHS and WEEE).

For further information on Quantum's Environmental Compliance and Global Citizenship, please consult the following Web site at <http://qcare.quantum.com>.

Disposal of Electrical and Electronic Equipment

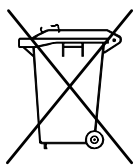

This symbol on the product or on its packaging indicates that this product should not be disposed of with your other waste. Instead, it should be handed over to a designated collection point for the recycling of electrical and electronic equipment. The separate collection and recycling of your waste equipment at the time of disposal will help to conserve natural resources and ensure that it is recycled in a manner that protects human health and the environment. For more information about where you can drop off your waste equipment for recycling, please visit the Quantum Web site at <http://qcare.quantum.com> or contact your local government authority, your household waste disposal service or the business from which you purchased the product.

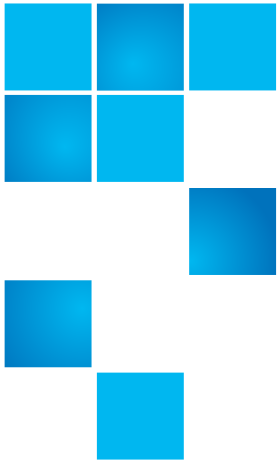

Appendix D

Converting LTO-7 Media to LTO-8 Type M

LTO-8 introduces a new media formatting option, the M format. The M format is used with LTO-8 tape drives and LTO-7 media.

When LTO-7 media is M formatted by an LTO-8 tape drive, the data capacity of the LTO-7 media is 9TB native, compared to 6TB of a standard formatted LTO-7 tape. The LTO-7 media to be M formatted must be unused, and after M formatting the media cannot be used in an LTO-7 drive.

A new bar code media identifier is used with M-formatted LTO-7 tapes. The last two characters of the bar code are "M8". Quantum strongly recommends that M-formatted media are labeled with M8 bar code labels.

The xTalk Management Console (xTalk) provides a script, `Initialize_Type_M_LTOC`, which can be used to M format LTO-7 media. xTalk supports formatting media in standalone tape drives and the SuperLoader 3.

Prior to M formatting LTO-7 media, the media must be loaded into the LTO-8 tape drive. Media must be loaded into the SuperLoader 3 using the remote management user interface.

The xTalk script `Format_Native_Density_LTOC` can be used to change an unused Type M tape back to the native LTO-7 format for use in an LTO-7 drive.

For additional information including details on running xTalk scripts and examples, refer to the *xTalk Management Console User's Guide* for your operating system:

xTalk Management Console User's Guide For Windows (81-81610-xx): http://downloads.quantum.com/dltsage/Windows/omxTalk_Windows_QuantumUsersGuide.pdf

xTalk Management Console User's Guide For Linux (81-81612-xx): http://downloads.quantum.com/dltsage/Linux/omxTalk_Linux_QuantumUsersGuide.pdf

xTalk Management Console User's Guide For MacOS (6-68370-xx) is also available.



Glossary

A

access Read, write, or update information on a storage medium, such as tape.

access time The interval between the time a request for data is made by the system and the time the data is available from the drive.

allocation The process of assigning particular areas of the media to particular data or instructions.

archiving The removal of data from the computer system on to secondary storage media that is safely stored away.

autoloader A robot that includes one tape drive and one or more magazines of tape cartridges. Autoloaders are used for unattended data backup.

B

backup A copy of a file, directory, or volume on a separate storage device from the original, for the purpose of retrieval in case the original is accidentally erased, damaged, or destroyed.

backward compatibility The ability of a current drive product to read tapes written on earlier model drives.

base plate An aluminum die casting that acts as the support platform for the other modules and for the drive enclosure. The base plate is standard 5.25 inch (133.35 mm) full-high form factor and includes the precision mounting holds used to install

Super DLTtape drives into a server or tape library. The TCM acts as the prime base plate for the Super DLTtape system.

bus A communication pathway between components in a computer system.

C

C Celsius. A measurement of temperature where 0 degrees is the freezing and 100 degrees is the boiling point of water.

cartridge receiver At tape insertion, the cartridge receiver assembly is responsible for guiding the tape into its operating position, opening its door, unlocking the cartridge brakes, and securing the tape for operation. At tape ejection, the cartridge receiver assembly reverses the process and automatically ejects the tape a fixed distance from the front of the drive.

compressed capacity Capacity after data has been processed to reduce storage space while maintaining data integrity using either software or hardware.

cartridge tape module (CPTM) The Super DLTtape CTM contains the AMP media feature of Quantum's LGMR technology. The main function of the CTM is to provide the magnetic recording media used by the drive to store customer information. The CTM also provides the protective cartridge that allows the media to be removed and stored safely.

D

data compression A process that reduces the amount of storage space required to hold a particular block of data. Data transfer speed and total tape capacity are affected by the data compression achieved. In accordance with industry practice, a typical compression ratio is 2:1 of data storage. Actual compression ratios achieved are dependent on the redundancy of data files being recorded.

data control module (DCM) The DCM contains several of the functions and features of Quantum's LGMR technology, which is at the heart of the Super DLTtape technology. Of the five technologies that constitute the LGMR technology, two are found in the DCM. These are the POS and the MRC heads. The main functions of the DCM are to provide the path and guides

for all tape motion inside the drive and to write data to and read data from the tape.

device According to SCSI specification, up to eight SCSI devices can be connected to a single SCSI bus. Each SCSI device contains a SCSI ID number that can be set to 0 through 7.

device driver A low-level (usually kernel-mode) operating system component that enables a PC to communicate with peripheral devices such as fixed disk drives, CD-ROMs, and tape drives. Each kind of device requires a different driver. Device driver programs are loaded into memory at boot time.

DHCP Dynamic Host Configuration Protocol. Software that automatically assigns IP addresses to client stations logging onto a TCP/IP network.

differential A term referring to the electrical characteristics of the signal used on the SCSI bus interface. Differential signals minimize the effect of common mode signal noise and allow the SCSI bus to operate reliably over greater distances at a higher speed.

domain A group of computers, programs, and devices on a network administered as a unit with common procedures and rules for use by a specific group of users. A user logs on to the domain to gain access to the resources.

driver A software program allowing the operating system to control a device such as a library, printer, or video card. Many devices do not respond properly if the correct driver is not installed in the computer.

E

ECC Error Correction Code, also known as Error Checking and Correction. The incorporation of extra parity bits in transmitted data in order to detect errors that can be corrected by the controller.

EDC Error Detection Code. DLT tape drives include a 16-bit EDC with every 4 KB of user data. The EDC helps the drive detect and recover any errors that may occur.

EEPROM Electronically-Erasable Programmable Read Only Memory. An integrated circuit memory chip that can store programs and data in a non-volatile state. These devices, which are used to

store firmware in DLT tape drives, can be erased and reprogrammed with new data.

EMI Electromagnetic Interference. Electrical interference caused by electromagnetic radiation.

encoding The protocol by which particular data patterns are changed prior to being written on the tape surface as a pattern of On and Off or 1 and 0 signals.

erase The removal of data from a piece of media.

error A message that occurs when there is a loss of ability to interpret recorded data. Usually due to magnetic issues or defects in or on the media.

Error Correction Code See ECC.

Error Detection Code See EDC.

Ethernet a local-area network (LAN) protocol using high-speed communications at 10 megabits per second.

external drive A drive mounted in an enclosure, separate from the computer system enclosure, with its own power supply and fan, and connected to the system by a cable.

F

F Fahrenheit. A temperature measurement system where 32 degrees is the freezing point and 212 degrees is the boiling point of water.

FCC Federal Communications Commission. A United States agency responsible for enforcing communications related regulations stating how much radiation computers and other electronic equipment are allowed to emit.

Fibre Channel A Gigabit-speed network technology used for storage networking. Fibre Channel is standardized in the T11 Technical Committee of the International Committee for Information Technology Standards (INCITS). It has become the standard connection type for storage area networks in enterprise storage. Fibre Channel signaling is typically run on fiber optic cables. Fibre Channel protocol (FCP) is the interface protocol of SCSI on the Fibre Channel.

files A distinct group of data blocks.

file-by-file backup A recording method that records data a single file at a time as opposed to mirroring a tape or block of data.

firmware Permanent or semi-permanent instructions and data programmed directly into the circuitry of programmable read-only memory or electronically-erasable programmable read-only memory chips. Used for controlling the operation of the computer or tape drive. Distinct from software, which is stored in random access memory and can be altered with ease.

format A magnetic track pattern that specifies the locations of the tracks and sectors. This information must exist on a tape before it can store any user data. Formatting erases any previously stored data.

formatted capacity The amount of room left to store data on a tape after writing the sector headers, boundary definitions, and timing information during a format operation.

Form Factor 1 The industry standard that defines the physical, external dimensions of a particular device.

Form Factor 2 The general geometric dimensions of a drive or width of a piece of tape media.

FTP File Transfer Protocol. A protocol used to transfer files over a TCP/IP network.

full height Dimensions of a drive that meet standard height requirements, usually 3.25 inches (82.55 mm) for a tape or disk drive product.

G

GB Gigabyte. A unit of measurement equal to 1 million kilobytes.

GHz Gigahertz. A measurement of frequency that equals one thousand million Hz, or one thousand MHz. Speeds for computer microprocessors, buses, and interfaces are often measured in GHz.

H

half height Standard drive size equivalent to half the vertical space of a 5.25 inch (133.35 mm) drive.

hard drive A drive that reads and writes data on a hard disk. The terms hard drive and hard disk are often used interchangeably.

- hard error** A data error that persists when the tape is reread, usually caused by defects in the physical surface.
- head** The tiny electromagnetic coil and metal pole used to create and read back the magnetic patterns on the tape. Also known as the read/write head.
- head life** The length of time a tape drive head will function without replacement or repair, usually measured in hours of use.
- Hierarchical Storage Management (HSM)** A method of storing massive amounts of data in tape libraries that allows for easy and rapid recall of the material. Due to the lowering cost of disk drives, HSM has yet to reach its full potential.
- HTTP** Hypertext Transfer Protocol. A protocol for exchanging files between computers connected to the Internet.
- Hz** Hertz. A unit of frequency measurement that equals 1 cycle per second. Computers and electronic devices are often measured in kilohertz (kHz), megahertz (MHz), gigahertz (GHz), or terahertz (THz).

I

- ISV** Independent Software Vendor.
- image backup** A backup option that takes a “snapshot” of an entire system by writing a volume image to tape sector-by-sector, rather than file-by-file. This method of backup is very fast and allows companies to backup critical information in a limited backup window.
- interface** A hardware or software protocol, contained in the electronics of the tape controller and tape drive that managed the exchange of data between the drive and computer. The most common interfaces for small computer systems are AT (IDE) and SCSI.
- internal drive** A drive mounted inside one of a computer’s drive bays.
- Internet** A worldwide network of computer servers originally developed by the federal government as a communication system in the event of nuclear war or other wide-scale disaster.
- intranet** A private version of the Internet that provides a cost-effective way to publish critical information and provide an interactive communication path for heterogeneous systems.

IP Internet Protocol. A communications protocol which contains a network address and routes a message to a different network.

J

jumper A tiny connector box that slips over two pins that protrude from a circuit board. The jumper can be moved to change electrical connectors. When in place, the jumper connects the pins electrically. Some board manufacturers use dual in-line package (DIP) switches instead of jumpers.

K

KB Kilobyte. A unit of measure consisting of 1,024 bytes.

kHz Kilohertz. A measurement of frequency that equals 1000 Hz.

L

LAN Local Area Network. A computer network covering a relatively small area. A LAN usually is confined to a building or a few nearby buildings. A LAN can be connected to another LAN over any distance through telephone lines and radio waves to form a wide area network (WAN).

LCD Liquid Crystal Display. The technology used by portable computer and flat-panel displays. The Operator Control Panel on the front of the SuperLoader is an LCD screen.

Lempel-Ziv Algorithm A data compression technique used in all DLT tape drives. Named after Abraham Lempel and Jacob Ziv.

library system A system that uses a robotic mechanism to automatically load and unload tape cartridges into one or more tape drives. Distinguishable from stackers and autoloaders in their ability to provide random access to tape cartridges. The DLTstor is a tape library system offered by Quantum Corporation.

linear recording Recording technology in which data is written in tracks that run the length of the tape media. Contrast with helical scan technology which records data diagonally across the tape.

-
- M**
- MB** Megabyte. A unit of measurement equal to 1 million bytes.
- MCBF** Mean Cycles Between Failures. This is average cycle count between possible failures. A cycle is the movement of a cartridge from the tape drive to a magazine slot and the selection of another cartridge and moving that cartridge back to the drive.
- MHz** MegaHertz. A measurement of frequency in millions of cycles per second.
- MTBF** Mean Time Between Failures. Reliability rating indicating the expected failure rate of a product in power on hours (POH). Since manufacturers differ in the ways they determine the MTBF, comparisons of products should always take into account the MTBF calculation method.
- MTRR** Mean Time to Repair. The average time it takes to repair a drive that has failed for some reason. This only takes into consideration the changing of the major subassemblies such as the printed circuit board or sealed housing. Component-level repair is not included in this number as this type of repair cannot be performed in the field.
- media** The material or device used to store information in a storage subsystem, such as a tape or disk drive. DLTtape media is a high-grade metal particle (MP) formulation that takes advantage of the latest advances in binder chemistry. By combining both solid and liquid lubricants in the tape binder system, tape and head wear are reduced while repelling airborne particles that could affect read/write head performance. In addition, by using a uniform particle shape, a dense binding system, a smooth coating surface, and a specially selected base file, Quantum DLTtape half-inch cartridge tapes take advantage of shorter wavelength recording schemes to ensure read compatibility with future generations of DLT drives.
- Metal Particle (MP) tape** A magnetic recording media in which a flexible base is coated with a mixture of magnetic particles and a bonding agent. See also media.
- microprocessor** The integrated circuit chip that performs the bulk of data processing and controls the operation of all of the parts of the system.
- microsecond (μ s)** One millionth of a second (.000001 sec.).

millisecond (ms) One thousandth of a second (.001 sec.).

minicomputer A somewhat out-of-date term used to describe a class of multi-user computer that was one notch below a mainframe system. Minicomputer popularity fell with the rise in popularity of the networked PC. Today's server systems perform many of the functions that were once the domain of minicomputers.

Mission Critical Applications that are vital to a company or organization's well-being.

N

native mode Refers to the uncompressed storage capacity of a tape or disk subsystem. For instance, a DLT 7000 tape drive can store 35 GB in native mode and 70 GB with 2:1 compression.

near-on-line storage An application that uses a tape drive or tape automation system in much the same way as a hard disk drive. Provides easy access to large amounts of critical information.

O

overhead Command overhead refers to the processing time required by the controller, host adapter, or drive prior to the execution of a command. Lower command overhead yields higher drive performance.

overwrite To write data on top of existing data thus erasing the original data.

OEM Original Equipment Manufacturer.

P

parallel channel architecture Allows DLT tape drives to read/write multiple channels simultaneously providing an industry-leading data transfer rate in the DLT 7000 drive. With this architecture, data blocks are not required to be located on any particular track or in consecutive order. This channel-independent block structure provides a powerful write-error handling system that allows bad blocks to be rewritten on the next available command.

Partial Response, Maximum Likelihood PRML. A technology that allows a disk or tape drive's read channel to pack more data in the same amount of space on magnetic media.

peak transfer rate The maximum speed with which information moves inside a tape drive or between drive and host. Usually measured in megabytes per second.

performance A measure of the speed of the drive during normal operation. Factors affecting performance are seek times, transfer rate, and command overhead.

peripheral A device added to a system as a complement to the basic central processing unit (CPU), such as a disk drive, tape drive, or printer.

POH Power-on Hours. The unit of measurement for mean time between failure (MTBF), expressed as the number of hours that the drive is powered on. See MTBF.

POST Power-on Self Test. Diagnostics programs, loaded automatically by the BIOS, that perform basic tests on the major system components, such as memory, cartridge and magazine information. If no problems are detected during POST, the system continues the start-up process.

PRML See Partial Response, Maximum Likelihood.

Q

QIC Quarter Inch Cartridge. A tape storage subsystem that uses 0.25 inch (6.35 mm) wide media.

R

RAM Random Access Memory. an integrated circuit memory chip that allows information to be stored and retrieved by a microprocessor or controller. The information can be stored or accessed in any order, and all storage locations are equally accessible.

RAIT Redundant Array of Independent Tape Drives

random access The ability to directly locate any piece of data without having to read everything in memory or on disk.

read after write A mode of operation that has the computer read back each data block immediately after it is written on the tape, checking that the data read back is the same as recorded.

read/write head The mechanism by which data is recorded onto magnetic media in a tape drive system. See read after write.

Reed-Solomon error correction An error correction technique based on research done by Irving reed and Gustave Solomon at MIT's lincoln Laboratory in the 1960s. First used to check the accuracy of data received from the Voyager spacecraft.

restore To replace data on the hard drive from another media source.

ROM Read Only Memory. Integrated circuit chip containing programs and data that can be accessed and read but cannot be modified.

S

SCSI Small Computer System Interface. An American National Standards Institute (ANSI) interface between the computer and peripheral controllers. Apple MacIntosh systems and many UNIX operating system workstations use the SCSI interface.

scalability Refers to the capability provided by the DLT tape drive family to read tapes from previous generations of drives. Allows users to upgrade to a faster, higher capacity DLT drive, yet still be able to read tape recorded on an older system. The term also refers to the ability of DLT tape library systems to be upgraded with a higher performance DLT drive and thus provide more capacity and performance in the same footprint. See backward compatibility.

seek The movement of a read/write head to a specific data track.

self cleaning head Found in all DLT tape drives. Tiny ridges on either side of the DLT drive read/write head continuously wipe the tape clean as it passes over the head. This is why there is no periodic cleaning prescribed for DLT tape drives.

server A powerful computer system with a large hard disk drive that serves the information access and communication needs of multiple users. Often servers are dedicated to a particular function such as Internet access, printing, file management, backup, and network communications.

servo data Magnetic markings written on the media that guide the read/write heads to the proper position.

shelf life The length of time that a tape can be stored without losing its magnetic strength. For DLTtape media, this period is 30 years or more.

- shock rating** A rating, expressed in Gs which stands for multiples of gravity, of how much shock a tape drive can sustain without damage. Operating and non-operating shock levels are usually specified separately.
- SMTP** Simple Mail Transfer Protocol. An e-mail protocol on the Internet that defines the message format and the message transfer agent.
- SNMP** simple Network Management Protocol. A protocol that monitors and controls a network.
- SNTP** Simple Network Time Protocol. SNTP is based on NTP, the Network Time Protocol, an industry standard way for computers to synchronize their time to an external reference standard. NTP and SNTP are fully interoperable. Each consists of a client, for example the SuperLoader, which obtains the current time (in UTC) from either an SNTP server or an NTP one. SNTP and NTP are in wide use on the Internet. NTP is specified by RFC1305. SNTP is specified by RFC2030.
- soft error** A faulty data reading that does not recur if the same data is reread from the disk or corrected by ECC. Usually caused by power fluctuations or noise spikes.
- stacker** A tape automation system that sequentially loads and unloads tape cartridges. does not provide random access to cartridges of the data stored on them.
- stepper** A type of motor that moves in discrete amounts with each electrical pulse.
- supply reel** The reel of tape contained within the DLTtape cartridge. DLTtape IV, for example, contains 1,800 feet (548.64 m) of tape.
- surface** The side of the tape that is coated with the magnetic material for recording data.
- sustained transfer rate** The data transfer rate of a tape drive in native mode. for example, the DLT 7000 has a sustained transfer rate of 5 MB in native mode, and up to 10 MB at 2:1 compression.
- system manufacturers** Makers of computer systems and tape library systems.
- Symmetric Phase Recording (SPR)** A recording technique introduced with the DLT 7000 that writes data at alternating angles in a herringbone pattern thereby eliminating the need for guard bands between data tracks, and providing higher data density.

T

TPI Tracks per Inch. A DLT 7000 tape drive, for example, writes data a density of 416 tpi, or 208 tracks across the width of the half-inch DLTtape media.

take-up reel The reel inside every DLT tape drive onto which DLTtape media is wound. The in-the-drive take-up reel enables DLT tape systems to operate using a single-reel cartridge and thereby pack more tape and data into every cartridge.

tape path The path through which tape moves from the cartridge, past the read/write head, and onto the take-up reel. The patented DLT drive head guide assembly provides a gentle and solid path that ensures tracking accuracy and long tape life.

tar A UNIX operating system command that stands for “create tape archives” and/or extract files.

TCP/IP Transmission Control Protocol/Internet Protocol. A communications protocol which ensures that the total amount of bytes sent is received correctly, and also provides the routing information.

thin film A type of coating allowing very thin layers of magnetic material used on tape drive read/write heads. Media with thin film surfaces can store greater amounts of data.

track A linear or angled pattern of data written on a tape surface. DLT tape drives write information on multiple tracks simultaneously.

track-to-track seek time The time required for the read/write heads to move to an adjacent track.

transfer rate The rate at which the drive sends and receives data from the controller. Usually measured in megabytes per second. A DLT 7000 drive, for example, has a native transfer rate of 5 MB/s.

U

unformatted capacity The total number of usable bytes on the media, including the space that will be required later to record location, boundary definitions, and timing information. See also formatted capacity.

V

volume The quantity of information written on a piece of media. Typically measured in megabytes or gigabytes.

W

Write Once, Read Many (WORM) An optical disk technology that allows the drive to store and read back data but prevents the drive from erasing information once it has been written.

write-protected Files or media that cannot be changed. user write-protection when you want to protect data from being changed or destroyed. To write-protect most tape cartridges, slide the write-protect tab to the “locked” position.

Z

ZIF Zero Insertion Force. A type of socket or connector allowing a computer chip or bar code reader to be inserted or removed with no stress applied to either the chip or bar code reader and its respective socket.