

# **DISTILLATION COLUMN DESIGN AND ANALYSIS**

**8<sup>TH</sup> AICHE SOUTHWEST PROCESS TECHNOLOGY CONFERENCE**

**OCTOBER 6-7, 2016 | GALVESTON, TX**



CREATE AMAZING.

# AGENDA

- ▶ Introduction
- ▶ Types of Columns
- ▶ Distillation Principles
- ▶ Distillation Design: Eight Practical Steps
- ▶ Useful Resources

# DISTILLATION IS...

- ▶ a process in which a liquid or vapor mixture of two or more substances is separated into its **component fractions of desired purity**
- ▶ based on the fact that the vapor of a boiling mixture will be richer in the components that have lower boiling points
- ▶ a consumer of enormous amounts of energy in terms of cooling and heating
- ▶ a large contributor to plant operating costs, maybe more than 50%

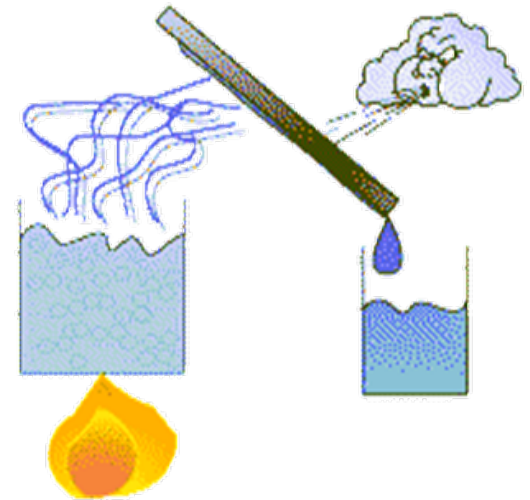

# AGENDA

- ▶ Introduction
- ▶ **Types of Columns**
- ▶ Distillation Principles
- ▶ Distillation Design: Eight Practical Steps
- ▶ Factors Affecting Operation
- ▶ Useful Resources

# COLUMNS

## ▶ Packed Bed Columns

- Used often for absorption and distillation of vapor-liquid mixtures
- Liquid flows downward through the packing
- Vapor flows upward through the packing

## ▶ Advantages

- Cost efficient
- Lower pressure drop
- Good for thermally sensitive liquids

## ▶ Disadvantages

- Packing can break during installation
- Maldistribution of liquid

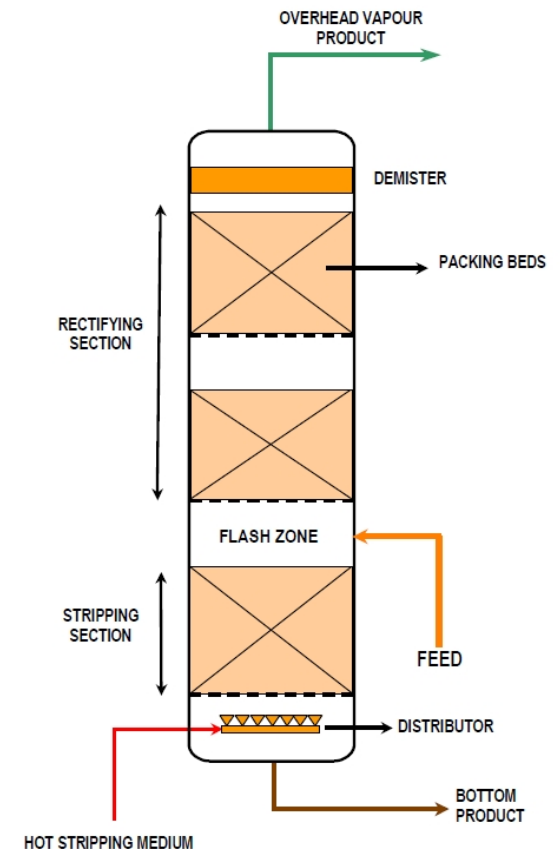

# COLUMNS

## ▶ Trayed Column

- The number of trays is dependent on the number of equilibrium stages

## ▶ Advantages

- Better distribution
- Can handle high liquid flow rates

## ▶ Disadvantages

- Higher pressure drop than packed columns
- Foaming can occur due to induced agitation

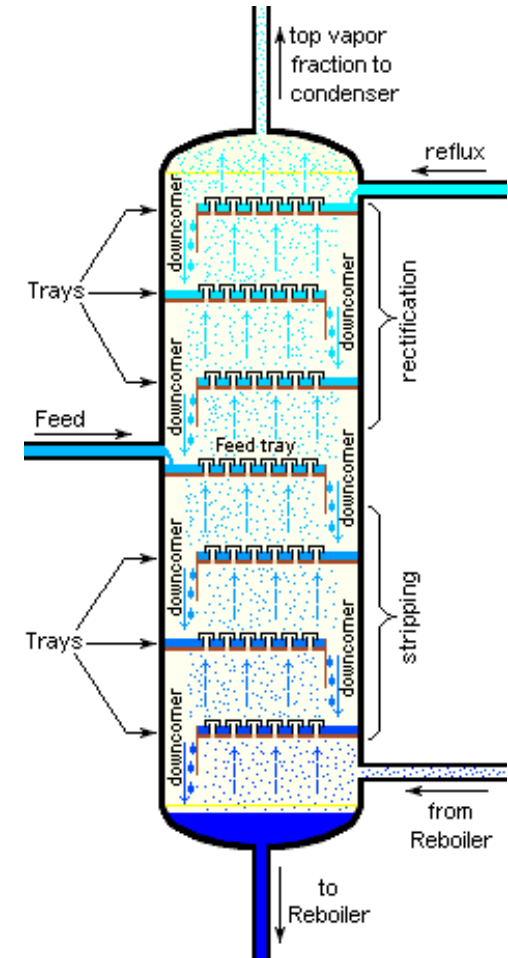

# USES

	DUAL FLOW	SIEVE	FIXED VALVE	MOVING VALVE
CAPACITY	VERY HI	HI	HI	HI
PRESS DROP	LO	MED	MED	MED/HI
ENTRAINMENT	LO	MED	MED	MED
TURNDOWN	1.5:1	2:1	2.5:1	4-5:1
FOULING TEND.	VERY LO	LO	LO	MED/HI
RELATIVE COST	<1	1	1.1	1.2
APPLICATION	FOULING	GENERAL	GENERAL	GENERAL

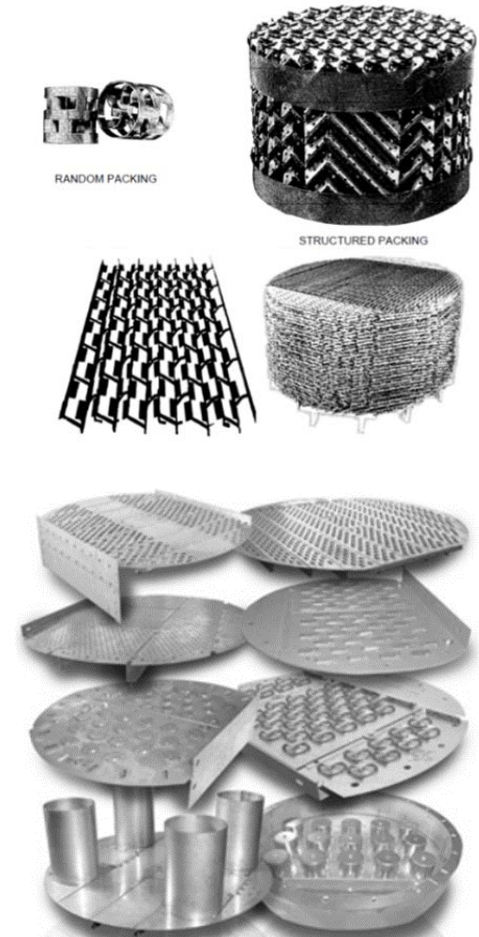

Ref.: H. Z. Kister, "Practical Distillation Technology"

# TRAYS VS. PACKING

TRAYS	PACKING
BETTER LIQUID DISTRIBUTION	LOWER PRESSURE DROP ( ~ 1/3 OF THAT OF TRAYS)
MORE PREDICTABLE PERFORMANCE	HIGHER CAPACITY IN REVAMPS
ENABLES TOWER FLEXIBILITY (MULTIPLE FEEDS, SIDE DRAWS, SIDE REBOILERS)	BETTER FOR SMALL DIAMETER APPLICATIONS
GOOD FOR CHEMICAL REACTION (DUE TO RESIDENCE TIME)	GOOD FOR CORROSIVES (CERAMIC, PLASTIC)
BETTER FOR LOW LIQUID RATES	HAS LOWER LIQUID HOLDUP
CAN HAVE HIGHER TURNDOWN	GOOD FOR BATCH DISTILLATION (HIGHER RECOVERY)

Ref.: H. Z. Kister, "Practical Distillation Technology"



# AGENDA

- ▶ Introduction
- ▶ Types of Column Internals
- ▶ **Distillation Principles**
- ▶ Distillation Design: Eight Practical Steps
- ▶ Useful Resources

# DISTILLATION PRINCIPLES

- ▶ A distillation column is a series of equilibrium flashes with two feeds and two product streams
- ▶ Exiting liquid is at bubble point
- ▶ Exiting vapor is at dew point
- ▶ Compositions obey the equation  $y_i = K_i \cdot x_i$

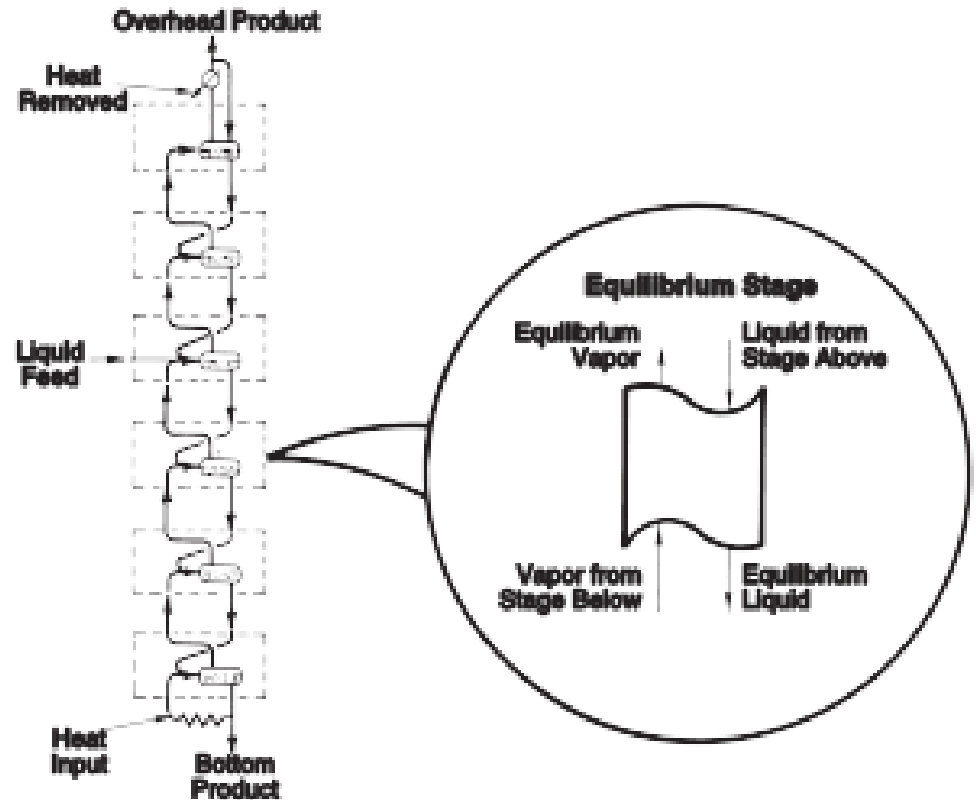

*“distillation” comes from Latin “de stilla”, or “of” “drop, trickle”*

# DISTILLATION PRINCIPLES

- A subcooled liquid (“A”) is heated, its concentration remains constant until it reaches the bubble-point, when it starts to boil (“B”)
- The vapor evolved during the boiling has the equilibrium composition given by “C”
- This is approximately 50% richer in component A than the original liquid
- **This difference between liquid and vapor compositions is the basis for distillation operations**

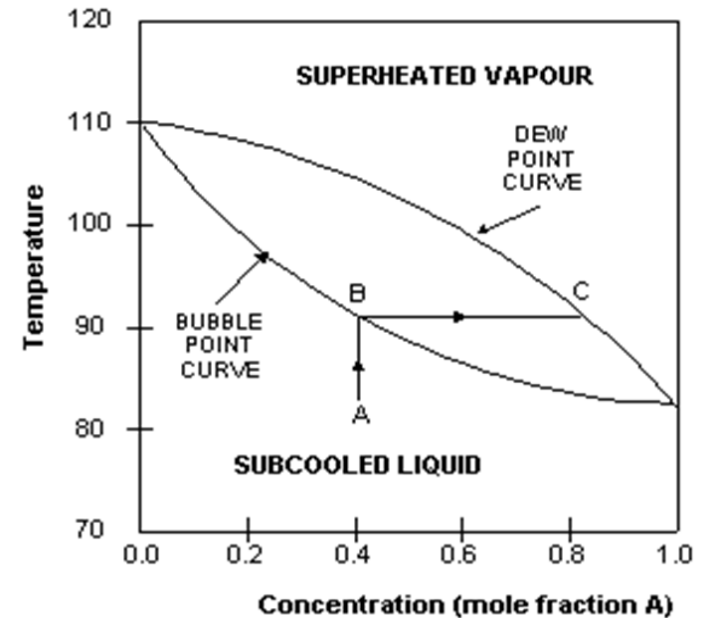

# AGENDA

- ▶ Introduction
- ▶ Types of Column Internals
- ▶ Distillation Principles
- ▶ **Distillation Design: Eight Practical Steps**
- ▶ Useful Resources

# COLUMN DESIGN: LIGHT

## PRACTICAL STEPS

1. Define product specification(s)
2. Choose an operating pressure
3. Choose appropriate VLE data
4. Calculate the number of theoretical trays
5. Select a tray efficiency
6. Select appropriate tower internals
7. Perform tower sizing and tray hydraulics
8. Select a process control scheme

# SPECIFICATION(S)

- Select light key and heavy key components
- There are three ways of specifying a desired product
  - A percentage **recovery** of a feed component in the overhead or bottom streams
  - A **composition** of one component in either product
  - A specific **physical property**, such as vapor pressure, for either product

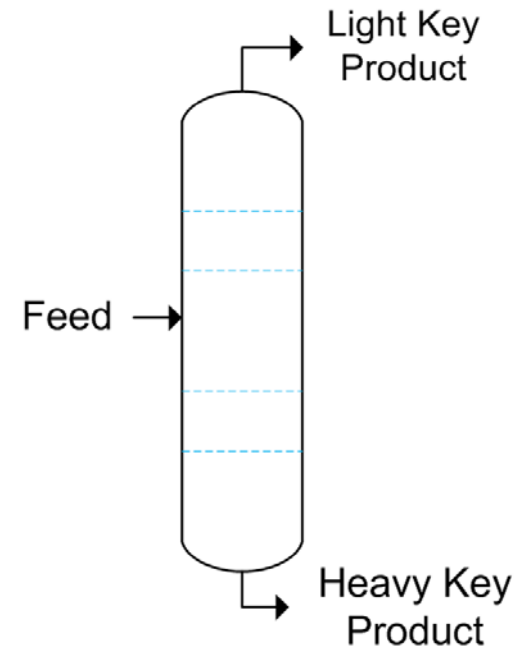

# OPERATING PRESSURE

- Operating pressure impacts all aspects of column design
- Some considerations, as pressure increases...
  - relative volatility mostly decreases, making separation more difficult
  - the minimum number of stages increases
  - required exchanger sizes may decrease
  - The column may get mechanically more costly

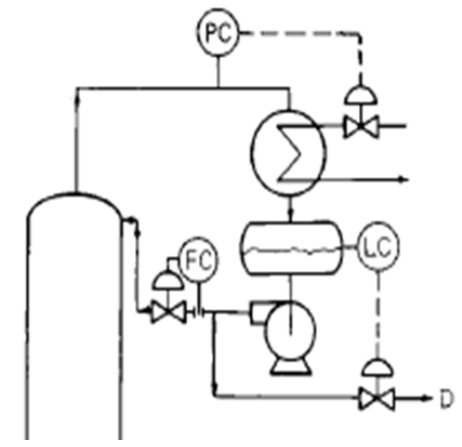

# OPERATING PRESSURE

FIG. 19-19

Typical Fractionator Parameters

	Operating Pressure, psig	Number of Actual Trays	Reflux <sup>1</sup> Ratio	Reflux <sup>2</sup> Ratio	Tray Efficiency, %
Demethanizer	200 - 400	18-26	Top Feed	Top Feed	45 - 60
Deethanizer	375 - 450	25-35	0.9 - 2.0	0.6 - 1.0	60 - 75
Depropanizer	240 - 270	30-40	1.8 - 3.5	0.9 - 1.1	80 - 90
Debutanizer	70 - 90	25-35	1.2 - 1.5	0.8 - 0.9	85 - 95
Butane Splitter	80 - 100	60-80	6.0 -14.0	3.0 - 3.5	90 - 100
Rich Oil Fractionator (Still)	130 - 160	20-30	1.75 - 2.0	0.35 - 0.40	Top 67 Bottom 50
Rich Oil Deethanizer	200 - 250	40	–	–	Top 25-40 Bottom 40-60
Condensate Stabilizer	100 - 400	16-24	Top Feed	Top Feed	50-75

<sup>1</sup>Reflux ratio relative to overhead product, mol/mol  
<sup>2</sup>Reflux ratio relative to feed, gal./gal.

Ref.: GPSA Engineering Data Book, Chapter 19.



# ENTHALPY DATA

- Choose correct VLE and enthalpy data ranges for property calculations
- Choose correct methods for calculating properties
- Inappropriate methods, models or data ranges can lead to poor results
- Close boiling systems are especially finicky to converge
  - Watch for non-ideality!
- See your favorite simulation guru for advice

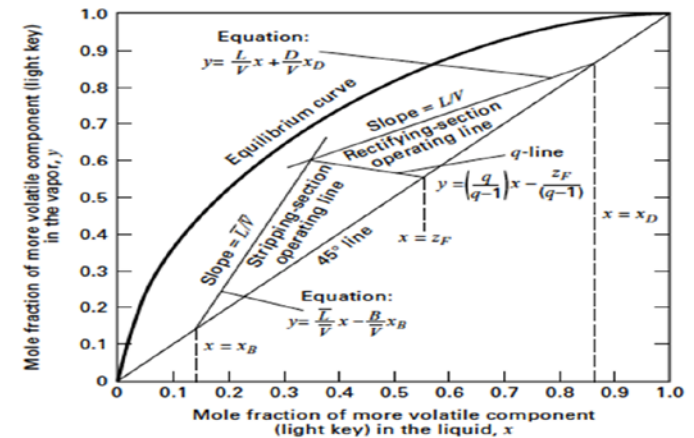

Ref.: Eric Carlson, “Don’t Gamble with Physical Properties”

# THEORETICAL TRAYS

- Calculate the minimum number of theoretical trays with the Fenske equation
- For a better tray count estimate, assume a reflux ratio and run cases in a simulator
  - In Aspen Plus, use *DISTWU* model
  - In HYSYS, use *Shortcut Column* model
- All column design work is typically done with theoretical trays

$$N_{\min} = \frac{\ln\left(\frac{x_D(1-x_B)}{x_B(1-x_D)}\right)}{\ln(\alpha_{AB})} - 1$$

Shortcut Method	Calculates For:
Winn	Minimum number of stages
Underwood	Minimum reflux ratio
Gilliland	Required reflux ratio for a specified number of stages or required number of stages for a specified reflux ratio

# EFFICIENCY

- ▶ Overall = # theoretical trays / # actual trays
- ▶ Point =  $(y_{out} - y_{in}) / (y_{eq} - y_{in})$
- ▶ Murphree = point efficiency, but over entire tray

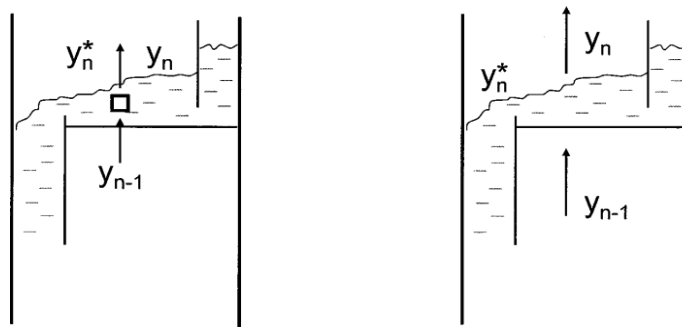

$$E = \frac{y_n - y_{n-1}}{y_n^* - y_{n-1}}$$

Ref.: H. Z. Kister, "Practical Distillation Technology"

# TYPICAL VALUES

FIG. 19-19

Typical Fractionator Parameters

	Operating Pressure, psig	Number of Actual Trays	Reflux <sup>1</sup> Ratio	Reflux <sup>2</sup> Ratio	Tray Efficiency, %
Demethanizer	200 - 400	18-26	Top Feed	Top Feed	45 - 60
Deethanizer	375 - 450	25-35	0.9 - 2.0	0.6 - 1.0	60 - 75
Depropanizer	240 - 270	30-40	1.8 - 3.5	0.9 - 1.1	80 - 90
Debutanizer	70 - 90	25-35	1.2 - 1.5	0.8 - 0.9	85 - 95
Butane Splitter	80 - 100	60-80	6.0 -14.0	3.0 - 3.5	90 - 100
Rich Oil Fractionator (Still)	130 - 160	20-30	1.75 - 2.0	0.35 - 0.40	Top 67 Bottom 50
Rich Oil Deethanizer	200 - 250	40	–	–	Top 25-40 Bottom 40-60
Condensate Stabilizer	100 - 400	16-24	Top Feed	Top Feed	50-75

<sup>1</sup>Reflux ratio relative to overhead product, mol/mol  
<sup>2</sup>Reflux ratio relative to feed, gal./gal.

Ref.: GPSA Engineering Data Book, 12<sup>th</sup> ed, pg. 19-15.

# LESSONS LEARNED

- Efficiency estimates in established processes are trouble-free with conventional internals
- With “high capacity” internals, be conservative with efficiency
- With first-of-a-kind systems, be conservative with efficiency
- There is always a learning curve with new “improved” internals --- be cautious

Ref.: H. Z. Kister, “Practical Distillation Technology”

# INTERNALS

- Determine appropriate tray or packing type based on application
- Consider:
  - Fouling tendency
  - Allowable pressure drop
  - Turndown requirements
- Use Kister's table or consult vendor
- Column zoning can help capacity

	DUAL FLOW	SIEVE	FIXED VALVE	MOVING VALVE
CAPACITY	VERY HI	HI	HI	HI
PRESS DROP	LO	MED	MED	MED/HI
ENTRAINMENT	LO	MED	MED	MED
TURNDOWN	1.5:1	2:1	2.5:1	4-5:1
FOULING TEND.	VERY LO	LO	LO	MED/HI
RELATIVE COST	<1	1	1.1	1.2
APPLICATION	FOULING	GENERAL	GENERAL	GENERAL

Ref.: H. Z. Kister, "Practical Distillation Technology"

# DIAMETER

- Estimate tower diameter using rules of thumb
  - “Heat Factor” of  $Q/d^2 = 350,000$ 
    - Duty in BTU/hr and diameter in feet
  - “General Factor” of  $(R+F)/d^2 = 250$ 
    - Flows in BPD and diameter in feet
- Refine diameter estimate with software tools
  - KGTower
  - SULCOL

# STEP 7: DETERMINE TRAY SPACING

- Use the table below as a guide for initial estimates
- Use KGTower or SULCOL software to rate a given internals type and tray spacing

DIAMETER	TRAY SPACING (1 PASS)	TRAY SPACING (2 OR MORE PASS)
2'-6" TO 3'-0"	18" OR 24"	----
3'-0" TO 10'-0"	24"	24"
10'-0" TO 20'-0"	30"	24"
20'-0" AND HIGHER	30" OR MORE	30" OR MORE



# TRAY PASSES

- Use the table below as a guide for initial estimates
- Use KGTower and SULCOL to rate a given number of tray passes

NUMBER OF PASSES	MECHANICAL MINIMUM DIAMETER	SUGGESTED MINIMUM DIAMETER
2	4'-6"	6'
3	7'-6"	9'
4	10'-0"	12'

# TYPICAL DESIGN VALUES

- ▶ Jet and downcomer flood < 85%
- ▶ Downcomer backup of clear liquid < 40% of tray spacing plus weir height
- ▶ Downcomer exit velocity < 1.5 ft/sec
- ▶ Dry tray drop < 2" of liquid or < 15% of tray spacing
- ▶ Total tray drop < 0.1 psi per tray
- ▶ Weir load < 80 gpm/ft for one pass and < 120 gpm/ft for two or more passes
- ▶ Head loss under downcomer of 0.06" to 1.0"
- ▶ Weir height of 2" to 3"

Ref.: H. Z. Kister, "Distillation Operation"

# CONTROL CONSIDERATIONS

- ▶ Only one of top product or bottom product composition may be controlled, unless somehow decoupled
- ▶ Composition control is readily made by temperature control unless some type of (expensive...) analysis is available
- ▶ Most columns use a material balance control scheme versus an energy balance scheme
- ▶ See Kister's "Distillation Operation", Chapters 16-19 for guidance

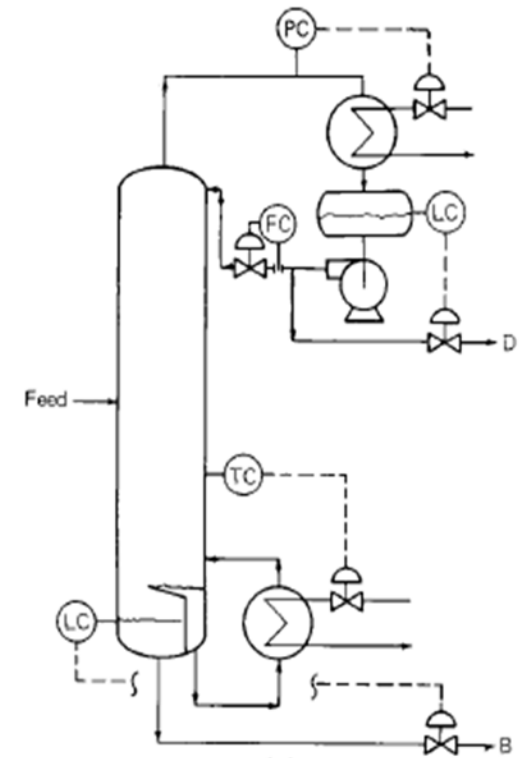

Ref.: H. Z. Kister, "Distillation Operation"

# PRESSURE CONTROL

- Pressure is THE prime distillation control variable
- Affects condensation, vaporization, temperatures, compositions, volatilities... almost everything
- Pair pressure with a manipulated variable that is most 'fast acting' for good, tight control
- There are many variations on basic pressure control such as hot vapor bypass

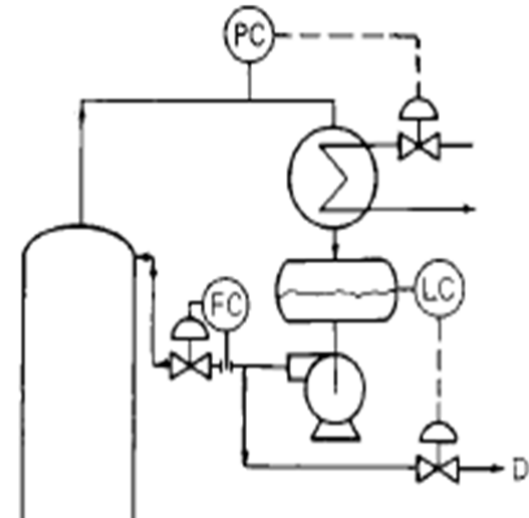

# PRACTICAL STEPS

1. Define product specification(s)
2. Choose an operating pressure
3. Choose appropriate VLE data
4. Calculate the number of theoretical trays
5. Select a tray efficiency
6. Select appropriate tower internals
7. Perform tower sizing and tray hydraulics
8. Select a process control scheme

# AGENDA

- ▶ Introduction
- ▶ Types of Column Internals
- ▶ Distillation Principles
- ▶ Distillation Design: Eight Practical Steps
- ▶ Useful Resources

# AGENDA

- ▶ Introduction
- ▶ Types of Column Internals
- ▶ Distillation Principles
- ▶ Distillation Design: Eight Practical Steps
- ▶ **Useful Resources**

# USEFUL REFERENCES

- ▶ Kister, H.Z., Distillation Operation
- ▶ Kister, H.Z., Distillation Design
- ▶ GPSA Handbook, Chapter 19, "Fractionation"
- ▶ Branan, Carl, Rules of Thumb for Chemical Engineers, Chapter 3, 4<sup>th</sup> ed., 2005, Gulf Publishing.
- ▶ Watkins, R.N., Petroleum Refinery Distillation
- ▶ Don't Gamble with Physical Properties for Simulations, Eric Carlson, Chemical Engineering Progress, October 1996, pp. 35-46.
- ▶ Seader, J. D., Ernest J. Henley, and D. Keith. Roper. Separation Process Principles: Chemical and Biochemical Operations. 3rd ed. Hoboken, NJ: Wiley, 2011. Print.
- ▶ "ENCYCLOPEDIA OF CHEMICAL ENGINEERING EQUIPMENT." Distillation Columns. N.p., n.d. Web. 11 Feb. 2015.
- ▶ Biegler, L., Grossmann, I., Westerberg, A., 1997, Systematic Methods of Chemical Process Design, Prentice Hall.
- ▶ Bravo, Jose L. and James K. Fair. "Distillation Columns." Chemical Engineering Progress January 1990: 19-Willis, M. J., Selecting a Distillation Column Control Strategy, Department of Chemical and Process Engineering, University of Newcastle, 2000.



# QUESTIONS AND DISCUSSION